

# AXOP31862/4/S

0.9 $\mu$ V Noise, 20V Rail-to-rail Output  
Operational Amplifiers (Dual/Quad)



Datasheet – May 2023

## Description

The AXOP31862 (dual), and AXOP31864 (quad) are ultra-low noise dual and quad mid voltage (3V to 20V) operational amplifiers (opamps) with rail-to-rail output swing capabilities. These devices are very suitable for applications where low noise, higher voltage operation, a small footprint, and high capacitive load drive are required. AXOP31862S and AXOP31864S are with Shutdown function.

## Features

- Supply voltages from 3V to 20V
- Input voltage noise (20Hz to 20kHz) 0.9 $\mu$ V
- Excellent THD+N 115dB
- Excellent SNR 115dB
- Rail-to-rail output
- Low input offset voltage:  $\pm 0.1$ mV typ
- Unity-gain bandwidth: 25MHz
- Low quiescent current (per opamp): 750 $\mu$ A typ @20V
- Shutdown function (AXOP31862S and AXOP31864S)

## Applications

- Infotainment system
- HVAC: heating, ventilating, and air conditioning
- Industrial control
- Test equipment
- Portable Equipment
- Active filters
- Data acquisition system

Table 1 Device Summary

Order code	Package	Packing	MOQ
AXOP31862A	eSOP8	Reel	2500
AXOP31862B	DFN8	Reel	3000
AXOP31862C	SOP8	Reel	4000
AXOP31862D	SOT23-8L	Reel	3000
AXOP31862E	DIP8	Tube	2000
AXOP31862SA	DFN10	Reel	5000
AXOP31862SB	SSOP10	Reel	2500
AXOP31864A	QFN14	Reel	6000
AXOP31864B	TSSOP14	Reel	3000
AXOP31864C	SOP14	Reel	2500
AXOP31864SA	QFN16	Reel	6000
AXOP31864SB	SOP16	Reel	4000

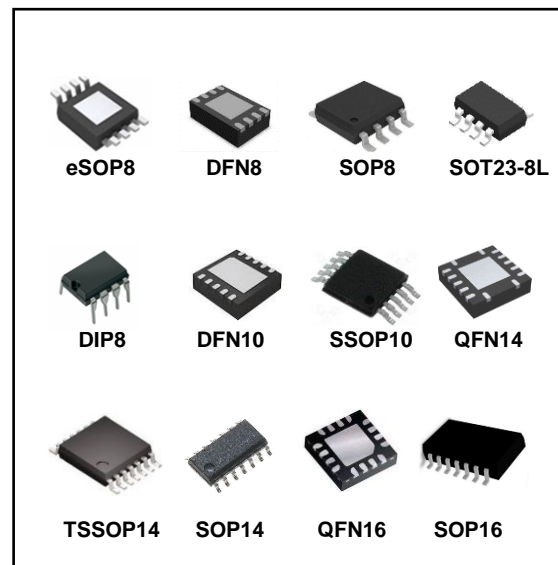

# Contents

Description.....	1
Features.....	1
Applications .....	1
1 Block Diagram and Application Circuit.....	4
2 Pin Description .....	5
2.1 AXOP31862A/B/C/D/E Pinouts.....	5
2.2 AXOP31862SA/B Pinouts.....	6
2.3 AXOP31864A/B/C Pinouts .....	7
2.4 AXOP31864SA/B Pinouts.....	8
3 Electrical Specifications.....	9
3.1 Absolute Maximum Ratings .....	9
3.2 Thermal Data.....	9
3.3 ESD.....	9
3.4 Electrical Characteristics .....	10
3.5 Typical Electrical Characteristics .....	12
4 Functional Description.....	15
4.1 Overview .....	15
4.2 Rail to Rail Output .....	15
4.3 Overload Recovery.....	15
4.4 EMI Rejection .....	15
4.5 Shutdown .....	15
5 Package Information .....	16
5.1 Package Dimensions.....	16
5.2 Marking Information.....	28
6 Packing Information.....	34
7 Revision History .....	35

## List of Figures

Figure 1 Block Diagram.....	4
Figure 2 Typical Application Circuit .....	4
Figure 3 AXOP31862A/B/C/D/E Pinouts .....	5
Figure 4 AXOP31862SA/B Pinouts .....	6
Figure 5 AXOP31864A/B Pinouts.....	7
Figure 6 AXOP31864SA/B Pinouts .....	8
Figure 7 Vos Distribution.....	12
Figure 8 Vos vs Input Common Mode Voltage .....	12
Figure 9 Vos vs Vs.....	12
Figure 10 Iq (per opamp) vs Input Common Mode Voltage .....	13
Figure 11 Iq (per opamp) vs Vs.....	13
Figure 12 THD+N vs Frequency.....	13
Figure 13 Large Signal Step Response.....	14
Figure 14 Settling Time .....	14
Figure 15 eSOP8 Mechanical Data and Package Dimensions .....	16
Figure 16 DFN8 Mechanical Data and Package Dimensions .....	17
Figure 17 SOP8 Mechanical Data and Package Dimensions .....	18
Figure 18 SOT23-8L Mechanical Data and Package Dimensions .....	19
Figure 19 DIP8 Mechanical Data and Package Dimensions.....	20
Figure 20 DFN10 Mechanical Data and Package Dimensions .....	21
Figure 21 SSOP10 Mechanical Data and Package Dimensions.....	22
Figure 22 QFN14 Mechanical Data and Package Dimensions .....	23
Figure 23 TSSOP14 Mechanical Data and Package Dimensions.....	24
Figure 24 SOP14 Mechanical Data and Package Dimensions .....	25
Figure 25 QFN16 Mechanical Data and Package Dimensions .....	26
Figure 26 SOP16 Mechanical Data and Package Dimensions .....	27
Figure 27 eSOP8 Marking Information .....	28
Figure 28 DFN8 Marking Information .....	28
Figure 29 SOP8 Marking Information .....	29
Figure 30 SOT23-8L Marking Information .....	29
Figure 31 DIP8 Marking Information.....	30
Figure 32 DFN10 Marking Information .....	30
Figure 33 SSOP10 Marking Information.....	31
Figure 34 QFN14 Marking Information .....	31
Figure 35 TSSOP14 Marking Information.....	32
Figure 36 SOP14 Marking Information .....	32
Figure 37 QFN16 Marking Information .....	33
Figure 38 SOP16 Marking Information .....	33
Figure 39 Reel Packing Information .....	34

## List of Tables

Table 1 Device Summary .....	1
Table 2 Absolute Maximum Ratings .....	9
Table 3 Thermal Data .....	9
Table 4 ESD .....	9
Table 5 Electrical Characteristics .....	10
Table 6 Document Revision History .....	35

# 1 Block Diagram and Application Circuit

Figure 1 Block Diagram

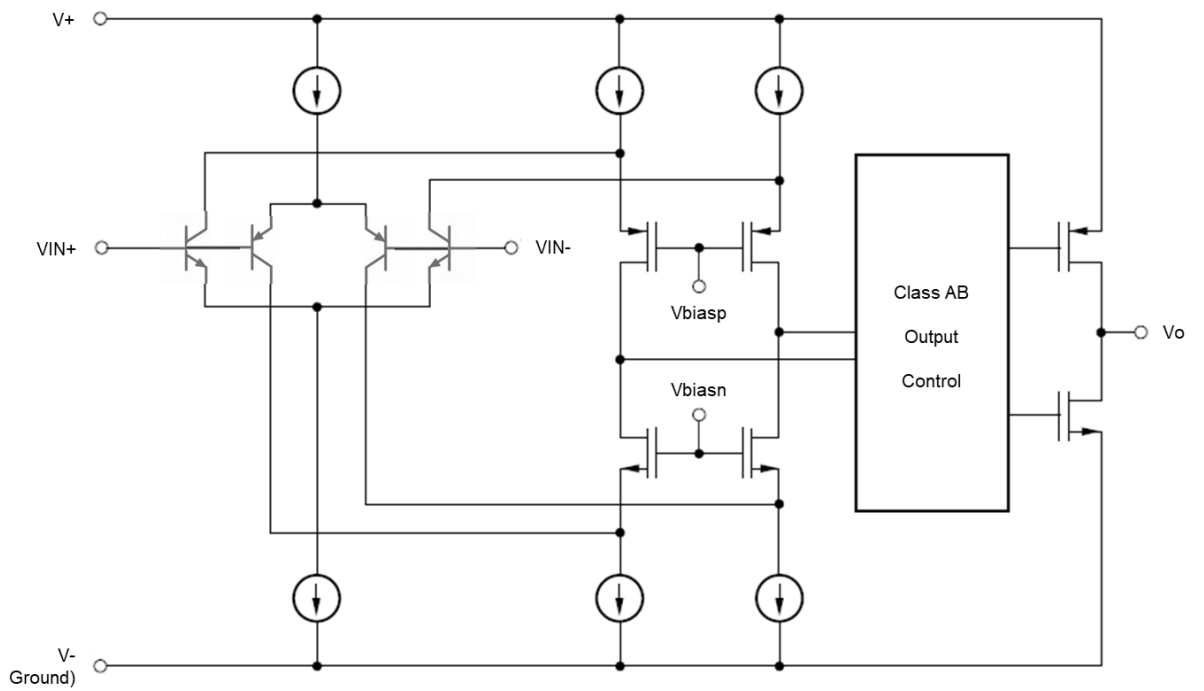
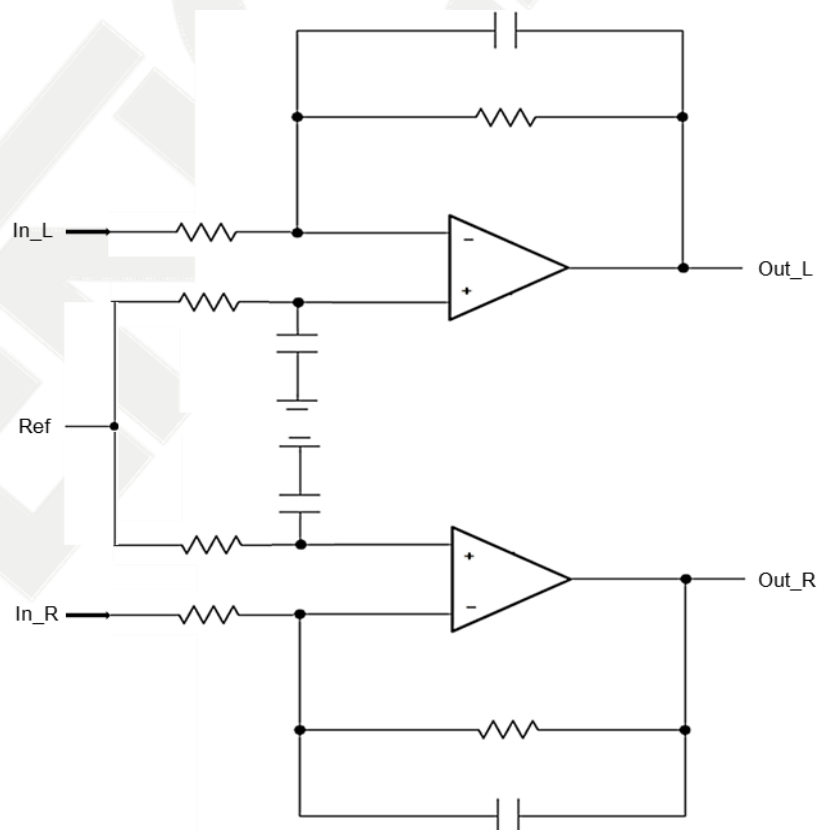

Figure 2 Typical Application Circuit (Stereo Sound Input Amplifier)



## 2 Pin Description

### 2.1 AXOP31862A/B/C/D/E Pinouts

Figure 3 AXOP31862A/B/C/D/E Pinouts

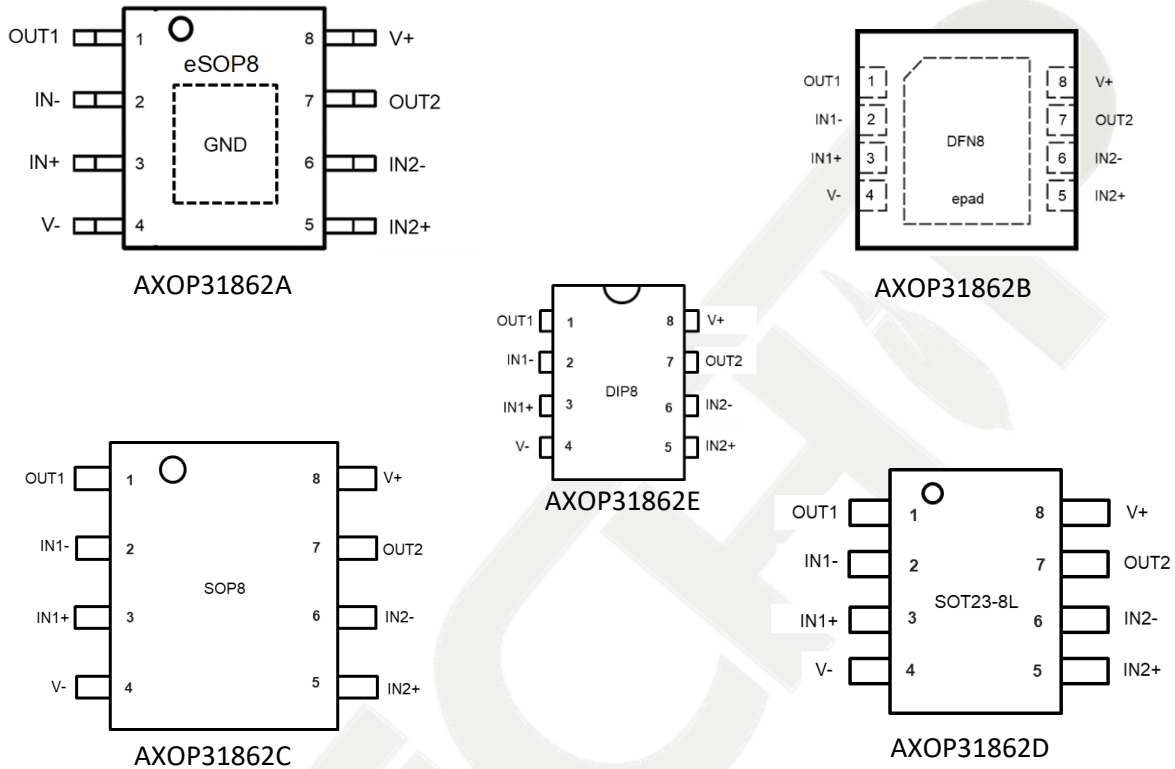

Pin number	Pin name	Description
1	OUT1	Output 1
2	IN1-	Inverting input 1
3	IN1+	Non-inverting input 1
4	V-	Negative supply or ground
5	IN2+	Non-inverting input 2
6	IN2-	Inverting input 2
7	OUT2	Output 2
8	V+	Positive supply

## 2.2 AXOP31862SA/B Pinouts

Figure 4 AXOP31862SA/B Pinouts

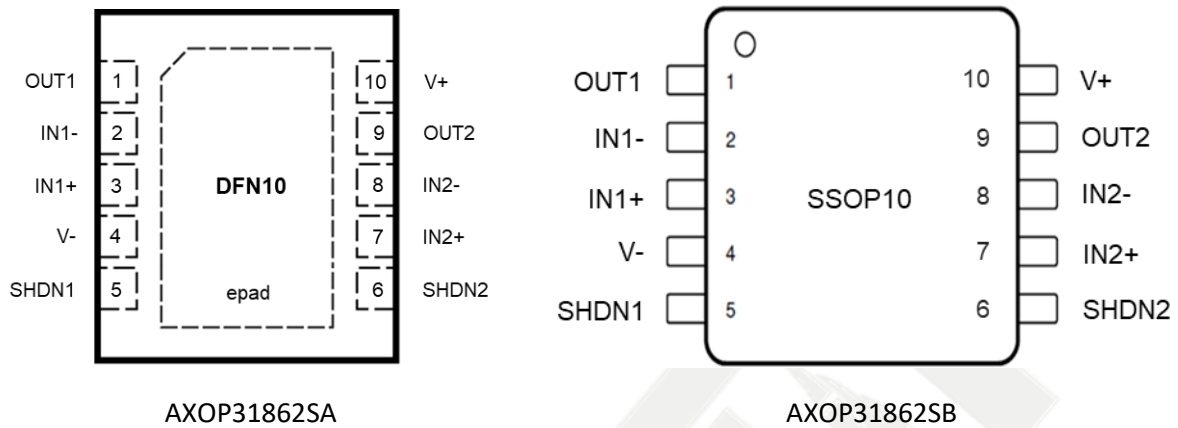

Pin number	Pin name	Description
1	OUT1	Output 1
2	IN1-	Inverting input 1
3	IN1+	Non-inverting input 1
4	V-	Negative supply or ground
5	SHDN1	Shutdown1: "High" = opamp 1 disabled Shutdown1: "Low" = opamp 1 enabled Shutdown1: "Float" = opamp 1 enabled
6	SHDN2	Shutdown2: "High" = opamp 1 disabled Shutdown2: "Low" = opamp 1 enabled Shutdown2: "Float" = opamp 1 enabled
7	IN2+	Non-inverting input 2
8	IN2-	Inverting input 2
9	OUT2	Output 2
10	V+	Positive supply

## 2.3 AXOP31864A/B/C Pinouts

Figure 5 AXOP31864A/B Pinouts

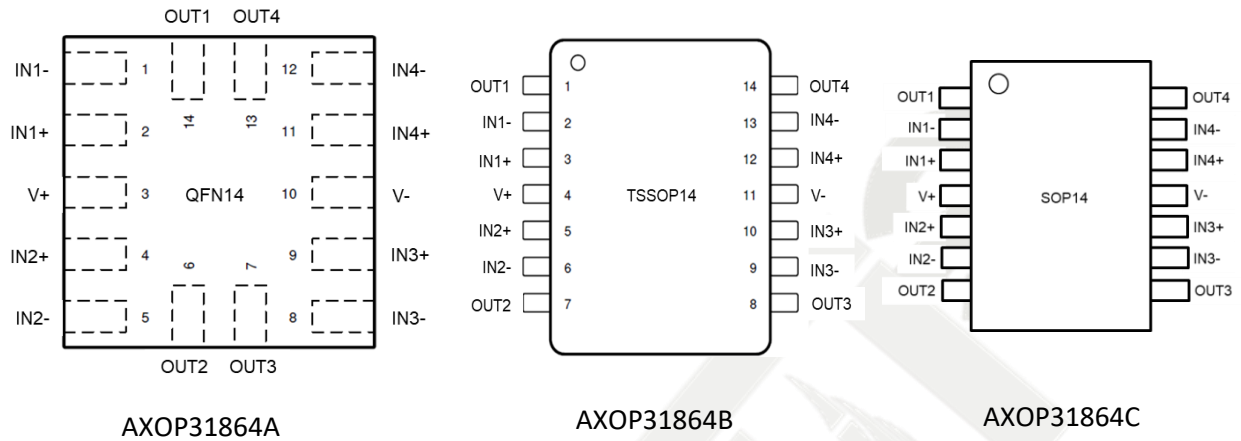

Pin number	AXOP31864A		AXOP31864B/C	
	QFN14 Pin name	QFN14 Description	TSSOP14/SOP14 Pin name	TSSOP14 / SOP14 Description
1	IN1-	Inverting input 1	OUT1	Output 1
2	IN1+	Non-inverting input 1	IN1-	Inverting input 1
3	V+	Positive supply	IN1+	Non-inverting input 1
4	IN2+	Non-inverting input 2	V+	Positive supply
5	IN2-	Inverting input 2	IN2+	Non-inverting input 2
6	OUT2	Output 2	IN2-	Inverting input 2
7	OUT3	Output 3	OUT2	Output 2
8	IN3-	Inverting input 3	OUT3	Output 3
9	IN3+	Non-inverting input 3	IN3-	Inverting input 3
10	V-	Negative supply or ground	IN3+	Non-inverting input 3
11	IN4+	Non-inverting input 4	V-	Negative supply or ground
12	IN4-	Inverting input 4	IN4+	Non-inverting input 4
13	OUT4	Output 4	IN4-	Inverting input 4
14	OUT1	Output 1	OUT4	Output 4

## 2.4 AXOP31864SA/B Pinouts

Figure 6 AXOP31864SA/B Pinouts

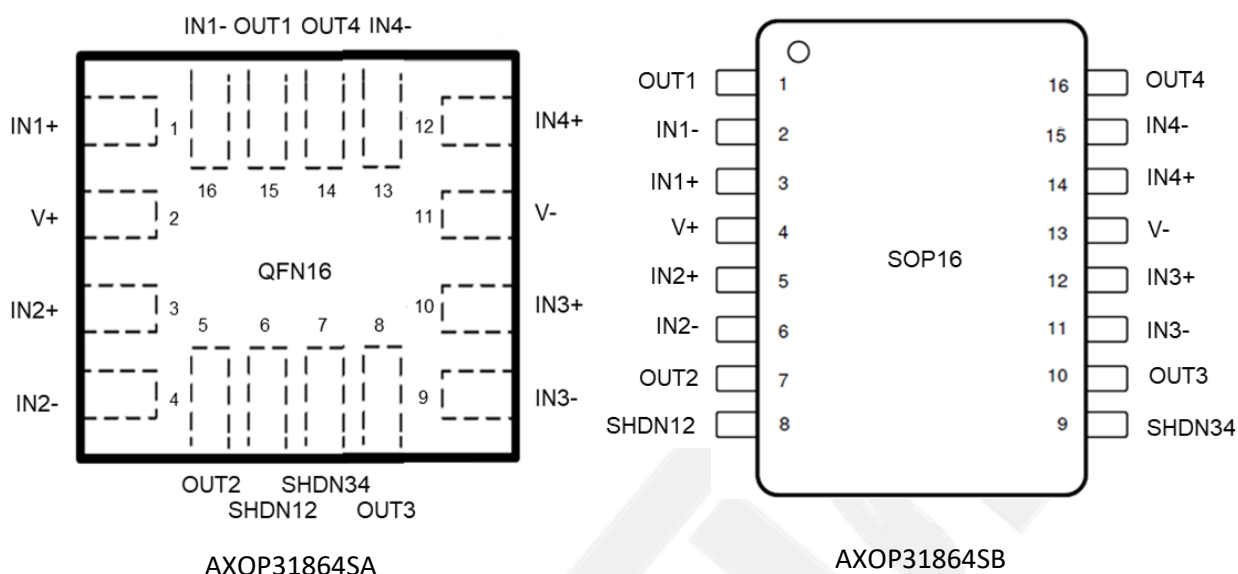

Pin number	AXOP31864SA		AXOP31864SB	
	QFN16 Pin name	QFN16 Description	SOP16 Pin name	SOP16 Description
1	IN1+	Non-inverting input 1	OUT1	Output 1
2	V+	Positive supply	IN1-	Inverting input 1
3	IN2+	Non-inverting input 2	IN1+	Non-inverting input 1
4	IN2-	Inverting input 2	V+	Positive supply
5	OUT2	Output 2	IN2+	Non-inverting input 2
6	SHDN12	Shutdown12: "High" = opamp 1&2 disabled	IN2-	Inverting input 2
7	SHDN34	Shutdown34: "High" = opamp 3&4 disabled	SHDN12	Shutdown12: "High" = opamp 1&2 disabled
8	OUT3	Output 3	SHDN34	Shutdown34: "High" = opamp 3&4 disabled
9	IN3-	Inverting input 3	IN3-	Inverting input 3
10	IN3+	Non-inverting input 3	OUT3	Output 3
11	V-	Negative supply or ground	IN3-	Inverting input 3
12	IN4+	Non-inverting input 4	IN3+	Non-inverting input 3
13	IN4-	Inverting input 4	V-	Negative supply or ground
14	OUT4	Output 4	IN4+	Non-inverting input 4
15	OUT1	Output 1	IN4-	Inverting input 4
16	IN1-	Inverting input 1	OUT4	Output 4



## 3 Electrical Specifications

### 3.1 Absolute Maximum Ratings

Table 2 Absolute Maximum Ratings

Symbol	Parameter	Value	Unit
V <sub>s</sub>	Supply voltage (V <sub>+</sub> ) - (V <sub>-</sub> )	-0.3 to +25	V
IN <sub>+</sub> , IN <sub>-</sub>	Input pin voltage	(V <sub>-</sub> ) - 0.5 to (V <sub>+</sub> ) +0.5	V
OUT	Output pin voltage	(V <sub>-</sub> ) - 0.5 to (V <sub>+</sub> ) +0.5	V
T <sub>j</sub>	Junction temperature	150	°C
T <sub>stg</sub>	Storage temperature	-55 to +150	°C

### 3.2 Thermal Data

Table 3 Thermal Data

Package	R <sub>th j-amb</sub>	R <sub>th j-case</sub>	Unit
eSOP8	60	10	°C/W
DFN8	43	5	°C/W
SOP8	136	77	°C/W
SOT23-8L	184	100	°C/W
DIP8	85	41	°C/W
DFN10	42	6	°C/W
SSOP10	160	45	°C/W
QFN14	47	4	°C/W
TSSOP14	113	62	°C/W
SOP14	106	64	°C/W
QFN16	45	5	°C/W
SOP16	80	30	°C/W

### 3.3 ESD

Table 4 ESD

Symbol	Parameter	Value	Unit
All pins	ESD (HBM)	±2,000	V

### 3.4 Electrical Characteristics

For  $V_s = (V_+) - (V_-) = 20V$  at  $T_a = 25^\circ C$ ,  $R_L = 10k\Omega$  connected to  $V_s/2$ ,  $V_{cm} = V_s/2$ , and  $V_{out} = V_s/2$  (unless otherwise noted).

Table 5 Electrical Characteristics

Symbol	Parameter	Test condition	Min	Typ	Max	Unit
$V_s$	Supply voltage ( $V_+$ ) - ( $V_-$ )		3		20	V
$T_a$	Operating ambient temperature		-40		85	$^\circ C$
<b>Power Supply</b>						
$I_q$	Quiescent current per amplifier	$V_s=20V, I_o=0mA$		750	900	$\mu A$
		all temp			1,200	$\mu A$
<b>Offset Voltage</b>						
$V_{os}$	Input offset voltage			$\pm 0.1$	$\pm 1$	mV
		all temp			$\pm 3$	mV
$dV_{os}/dT$	Drift	all temp		$\pm 0.4$		$\mu V/^\circ C$
PSRR	Power-supply rejection ratio	At DC		120		dB
Csep	Channel separation	At DC		120		dB
<b>Input Voltage Range</b>						
$V_{cm}$	Common mode voltage range	$V_s=3V$ to 20V	$(V_-)+1$		$(V_+)-1$	V
CMRR	Common mode rejection ratio	At DC		100		dB
<b>Input Bias Current</b>						
$I_b$	Input bias current				$\pm 1$	$\mu A$
$I_{os}$	Input offset current				$\pm 0.1$	$\mu A$
<b>Noise</b>						
$E_n$	Input voltage noise	$f=20Hz$ to 20kHz		0.9		$\mu V$
<b>Open Loop Gain</b>						
$A_{ol}$	Open loop voltage gain			130		dB
<b>Frequency Response</b>						
GBP	Gain bandwidth product	$G=+1, C_L=10pF$		25		MHz
SR	Slew rate	$G=+1, C_L=10pF$		8		$V/\mu s$
$T_s$	Settling time	To 0.1%, 2V step, $G=+1, C_L=10pF$		0.3		$\mu s$
THD+N	Total harmonic distortion + Noise (3 <sup>rd</sup> order filter; BW= 80kHz at -3dB.)	$V_s=20V, V_{cm}=10V, V_o=1V_{rms}, G=+1, f=1kHz$		115		dB
SNR	Signal to Noise Ratio	$V_s=20V, V_{in}=1V_{rms}, G=+1, f=1kHz$		115		dB
<b>Output</b>						
$V_o$	Voltage output swing from supply rails	$R_L=10k\Omega$		40	60	mV
		$R_L=2k\Omega$		150	200	

Isc	Short circuit current			±30		mA
		AXOP31862A only eSOP8 package		±200		mA
<b>Shutdown (AXOP31862S and AXOP31864S only)</b>						
Iqsd	Quiescent current per amplifier	Vs=3V to 20V, amplifier disabled, SHDN = "High"		20	40	μA
Vsd	Shutdown threshold	Vs=3V to 20V, amplifier disabled, SHDN = "High"	4			V
Vsdl	Low level shutdown threshold	Vs=3V to 20V, amplifier enabled, SHDN = "Float" or SHDN = "Low"			1	V
ton	Amplifier enable time	Vs=3V to 20V, full shutdown; G=+1, Vo = 0.9×Vs/2, RL connected to V-		10		μs
toff	Amplifier disable time	Vs=3V to 20V, G=+1, Vo=0.1×Vs/2, RL connected to V-		1		μs

Disable time (toff) and enable time (ton) are defined as the time interval between the 50% point of the signal applied to the SHDN pin and the point at which the output voltage reaches the 10% (disable) or 90% (enable) level.

### 3.5 Typical Electrical Characteristics

Figure 7 Vos Distribution

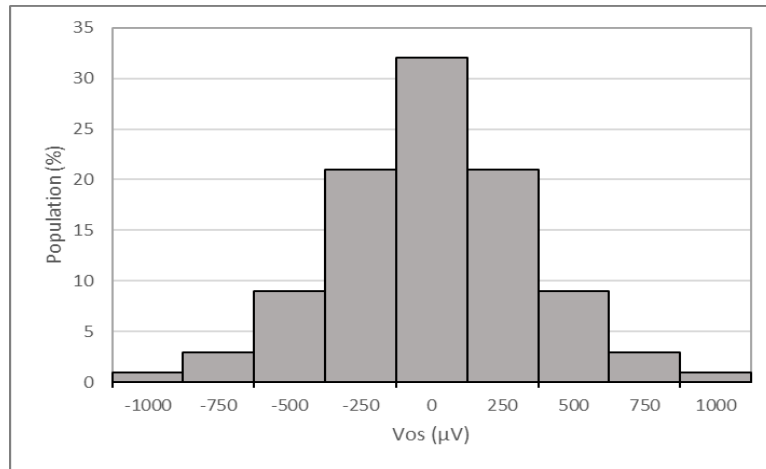

Figure 8 Vos vs Input Common Mode Voltage

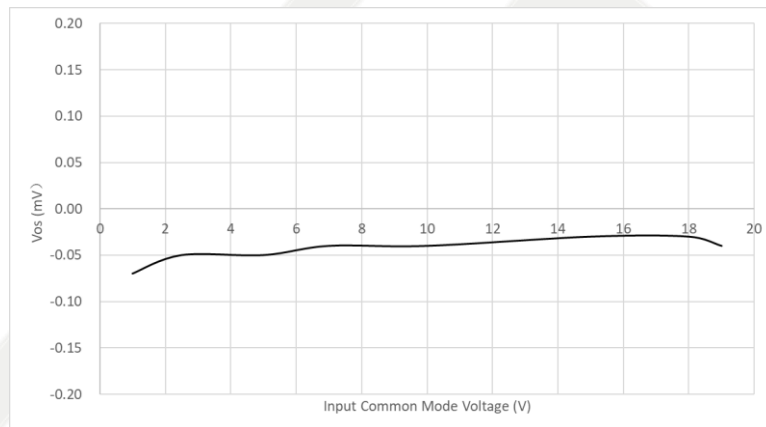

Figure 9 Vos vs Vs

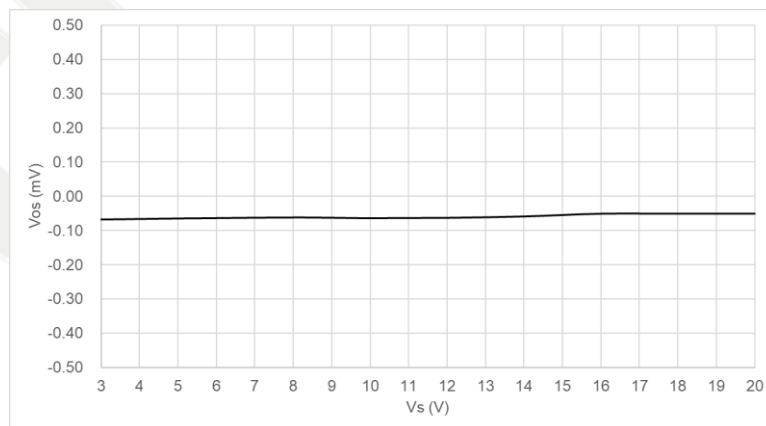

Figure 10 Iq (per opamp) vs Input Common Mode Voltage

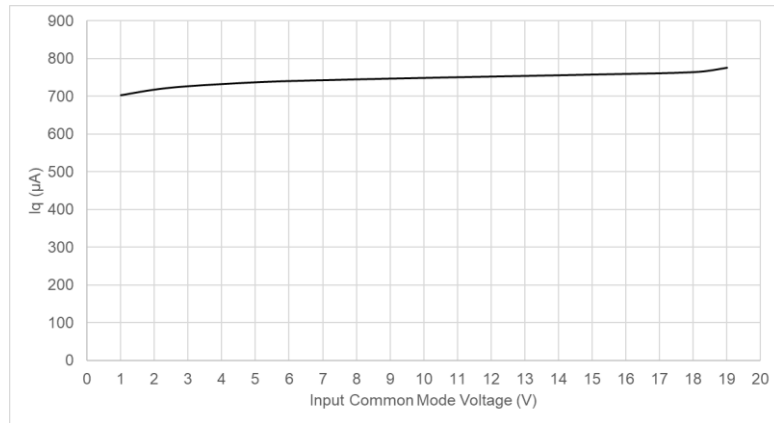

Figure 11 Iq (per opamp) vs Vs

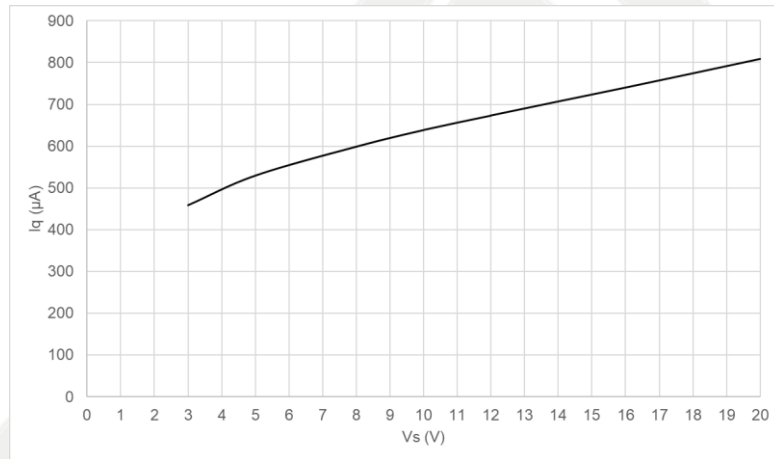

Figure 12 THD+N vs Frequency

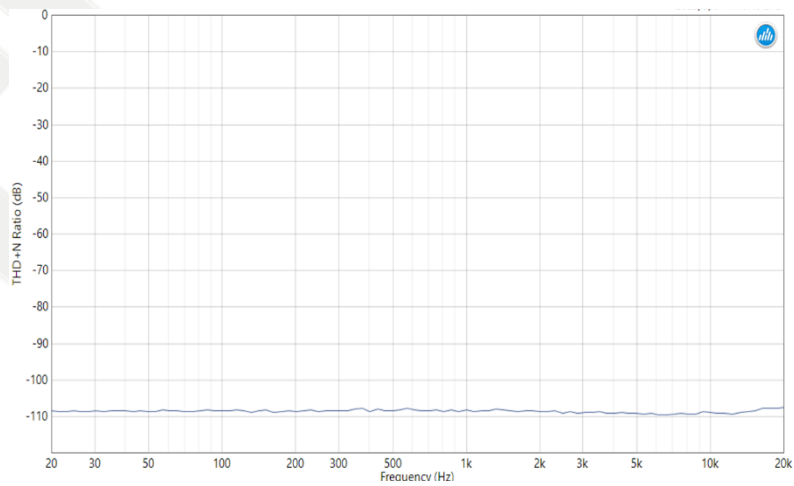

Figure 13 Large Signal Step Response

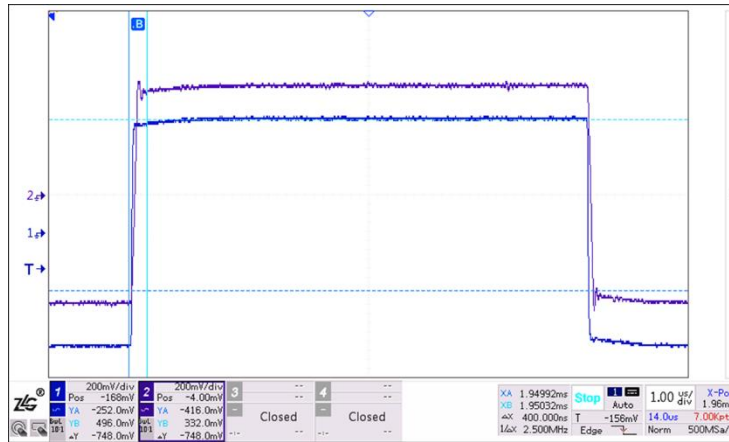
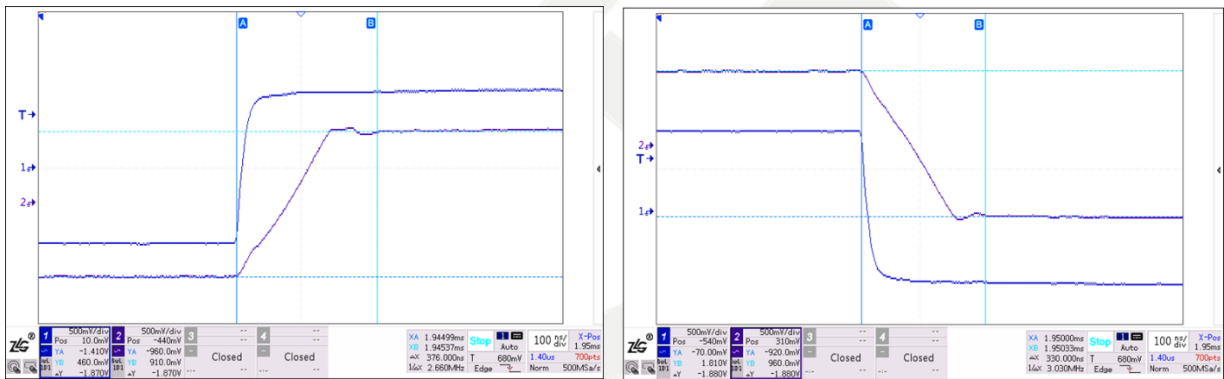

Figure 14 Settling Time



## 4 Functional Description

### 4.1 Overview

The AXOP3186x devices are a family of high voltage, rail-to-rail input and output opamps. These devices operate from 3V to 20V, are unity gain stable, and are designed for a wide range of applications and used in virtually any single supply application.

### 4.2 Rail to Rail Output

Designed as a high voltage operational amplifier, the AXOP3186x series delivers a robust output drive capability. A class AB output stage with common source Mosfets achieves full rail-to-rail output swing capability. For resistive loads of 10k $\Omega$ , the output swings to within 100mV (typ) of either supply rail, regardless of the applied power supply voltage. Different load conditions change the ability of the amplifier to swing close to the rails.

### 4.3 Overload Recovery

Overload recovery is defined as the time required for the opamp output to recover from a saturated state to a linear state. The output devices of the opamp enter a saturation region when the output voltage exceeds the rated operating voltage, because of the high input voltage or the high gain. After the device enters the saturation region, the charge carriers in the output devices require time to return to the linear state. After the charge carriers return to the linear state, the device begins to slew at the specified slew rate. The overload recovery time for the AXOP3186x family is approximately 20ns.

### 4.4 EMI Rejection

The AXOP3186x uses integrated electromagnetic interference (EMI) filtering to reduce the effects of EMI from sources such as wireless communications and densely populated boards with a mix of analog signal chain and digital components.

### 4.5 Shutdown

The AXOP3186xS has shutdown function. The amplifiers can be shut down by enabling the respective shutdown pin.

## 5 Package Information

### 5.1 Package Dimensions

Figure 15 eSOP8 Mechanical Data and Package Dimensions

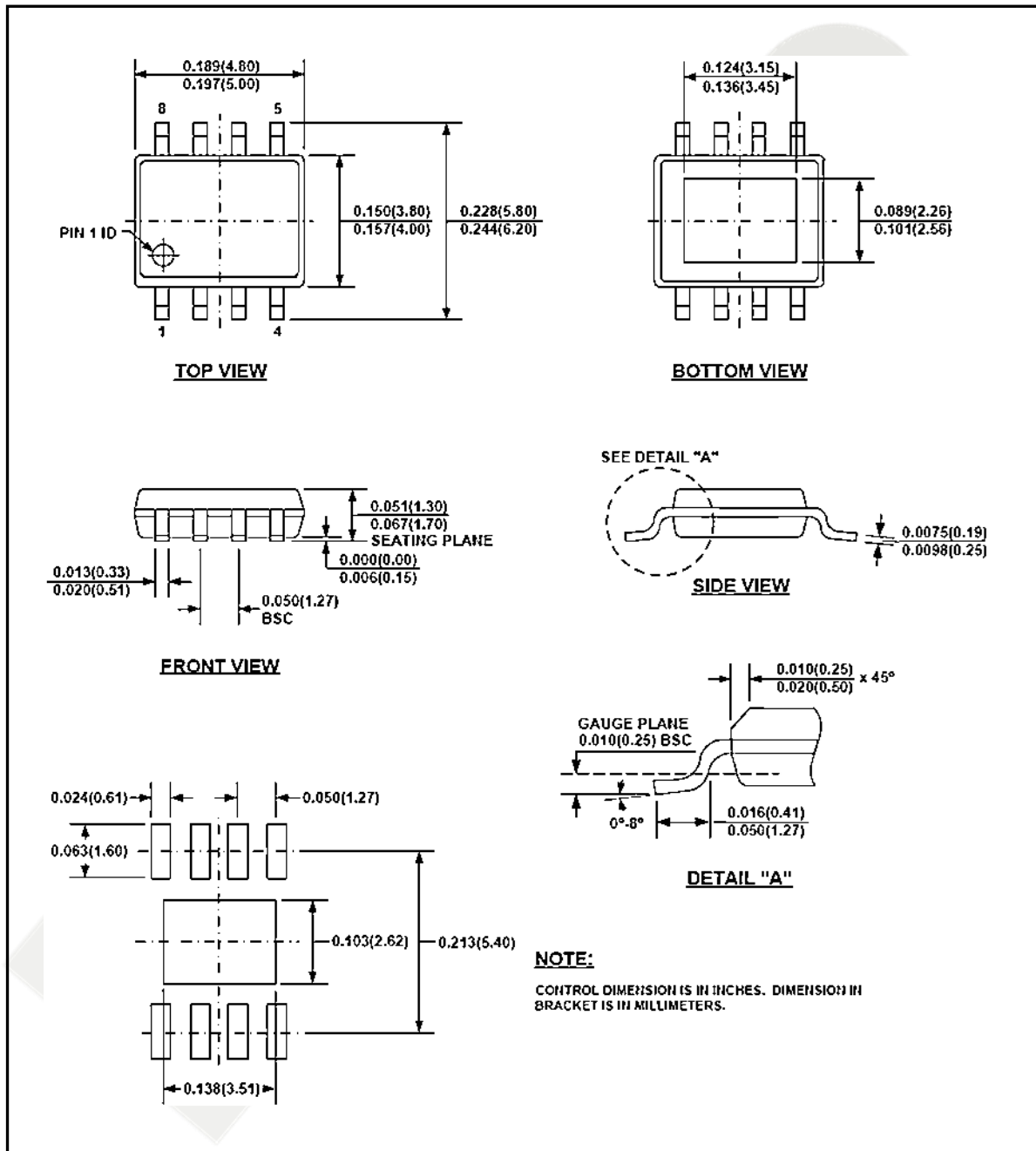
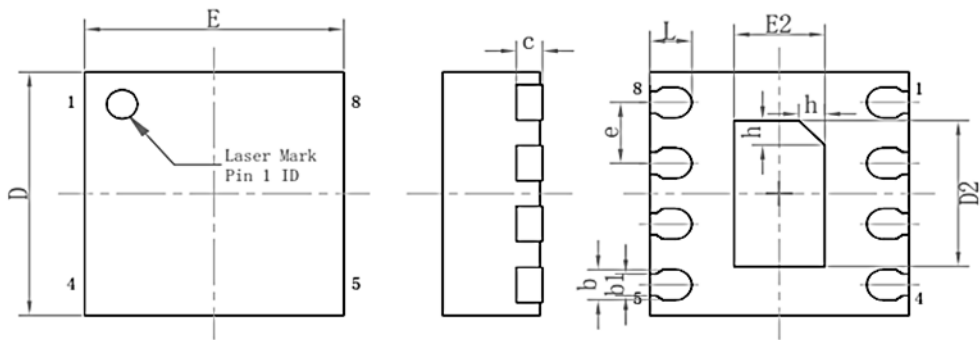



Figure 16 DFN8 Mechanical Data and Package Dimensions

	Min (mm)	Typ (mm)	Max (mm)		Min (mm)	Typ (mm)	Max (mm)
A	0.70	0.75	0.80	e	0.50BSC		
A1	0.00	0.02	0.05	E	1.95	2.00	2.05
b	0.18	0.25	0.30	E2	0.65	0.70	0.75
b1	0.18REF			L	0.25	0.30	0.35
c	0.20REF			h	0.15	0.20	0.25
D	1.95	2.00	2.05				
D2	1.15	1.20	1.25				



bottom view

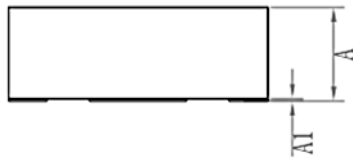

Figure 17 SOP8 Mechanical Data and Package Dimensions

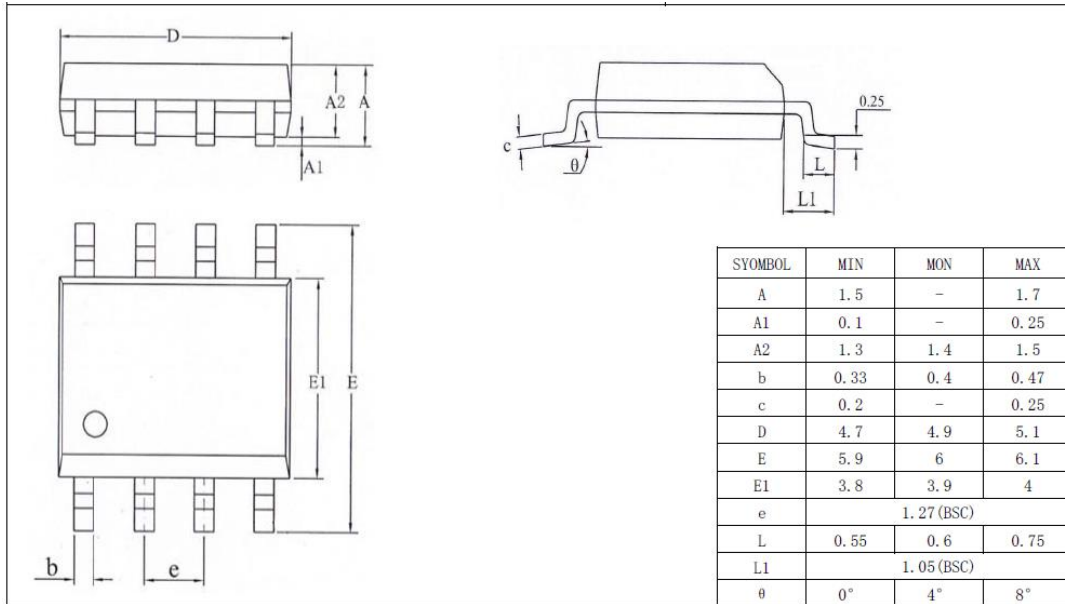

Figure 18 SOT23-8L Mechanical Data and Package Dimensions

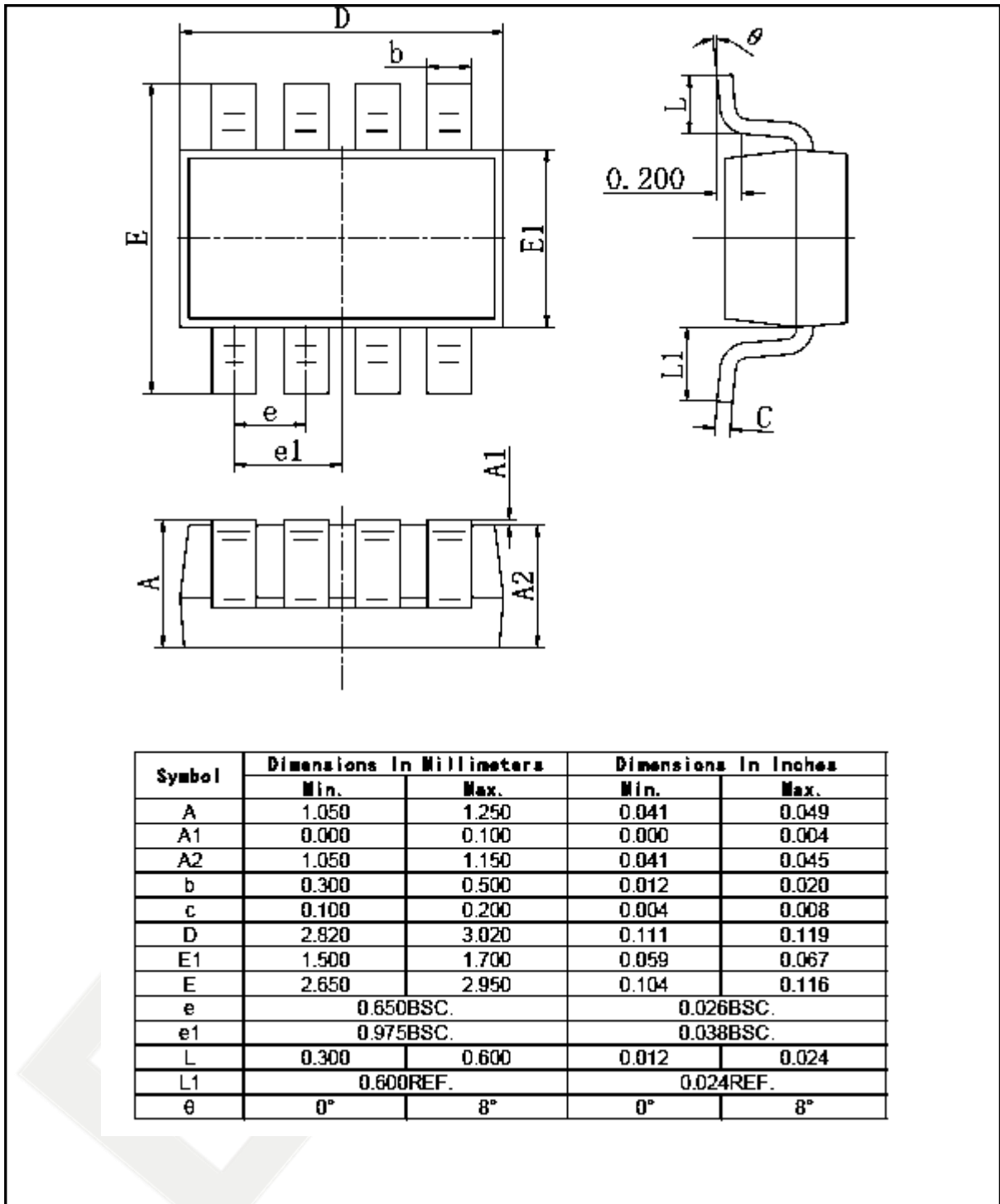
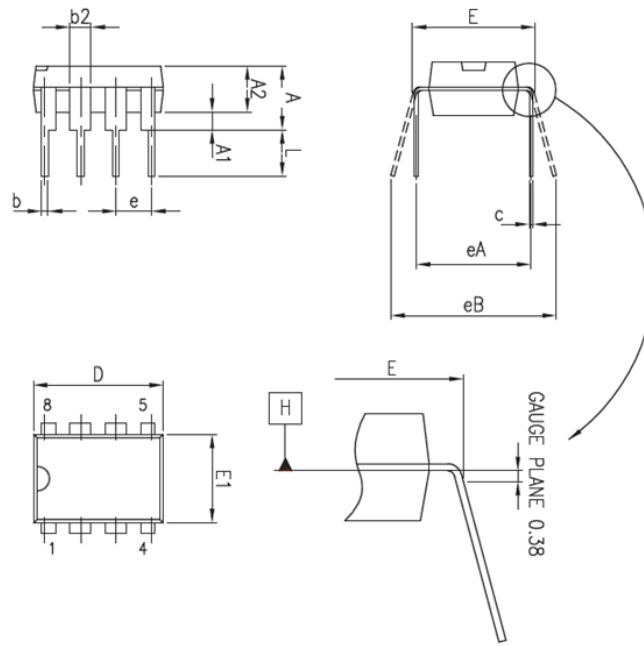

Figure 19 DIP8 Mechanical Data and Package Dimensions



Ref.	Dimensions					
	Millimeters			Inches		
	Min.	Typ.	Max.	Min.	Typ.	Max.
A			5.33			0.210
A1	0.38			0.015		
A2	2.92	3.30	4.95	0.115	0.130	0.195
b	0.36	0.46	0.56	0.014	0.018	0.022
b2	1.14	1.52	1.78	0.045	0.060	0.070
c	0.20	0.25	0.36	0.008	0.010	0.014
D	9.02	9.27	10.16	0.355	0.365	0.400
E	7.62	7.87	8.26	0.300	0.310	0.325
E1	6.10	6.35	7.11	0.240	0.250	0.280
e		2.54			0.100	
eA		7.62			0.300	
eB			10.92			0.430
L	2.92	3.30	3.81	0.115	0.130	0.150

Figure 20 DFN10 Mechanical Data and Package Dimensions

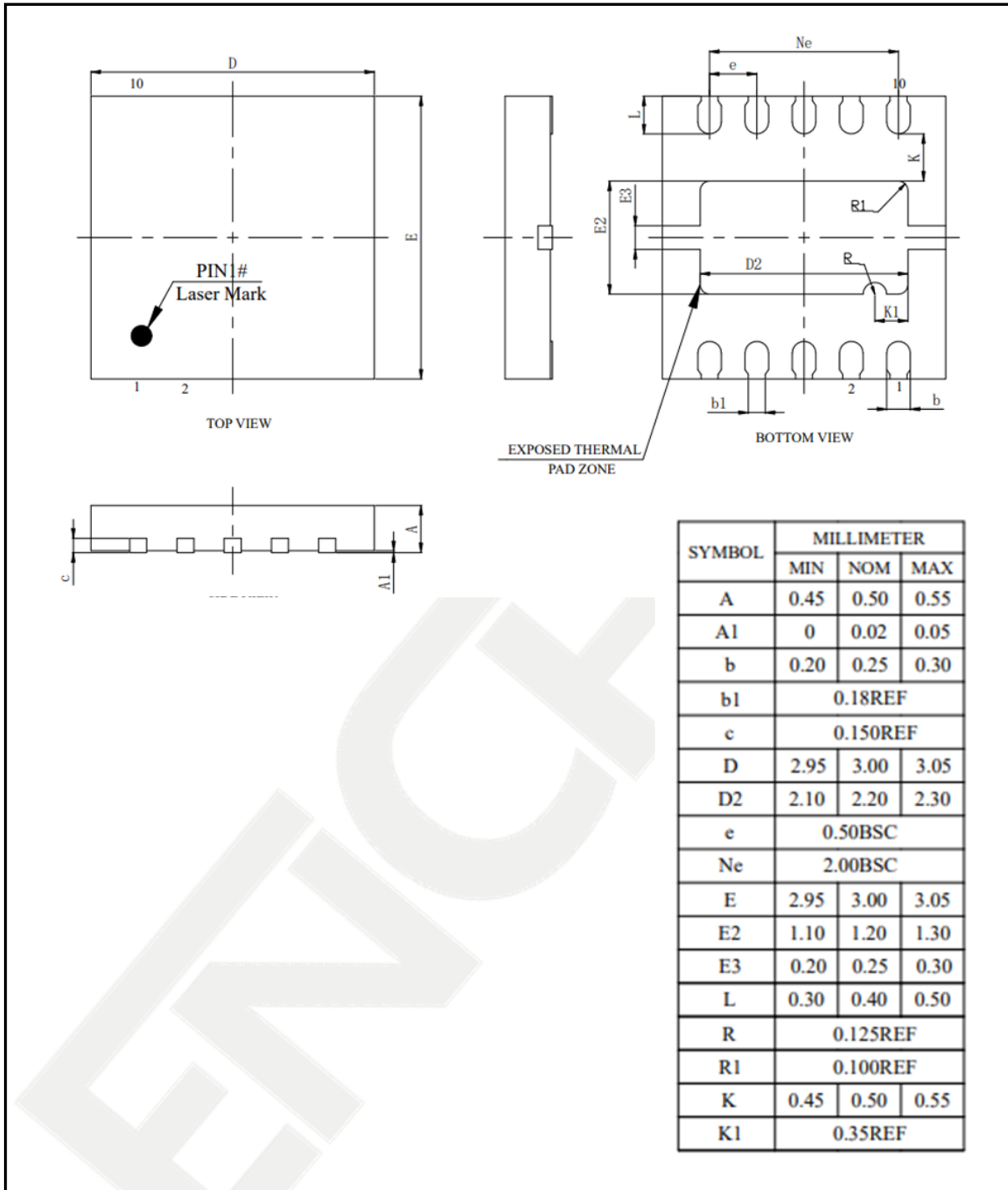

Figure 21 SSOP10 Mechanical Data and Package Dimensions

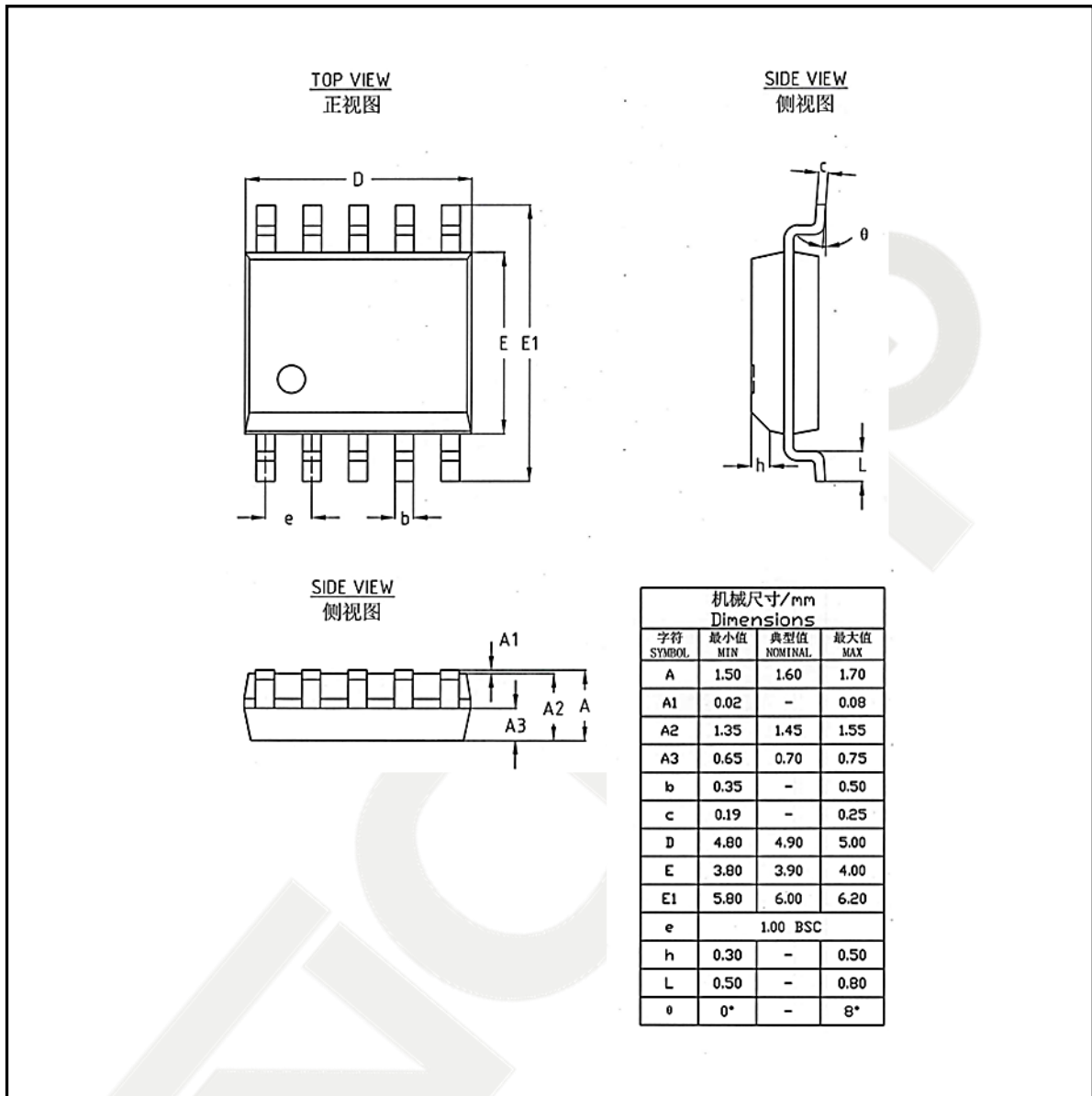

Figure 22 QFN14 Mechanical Data and Package Dimensions

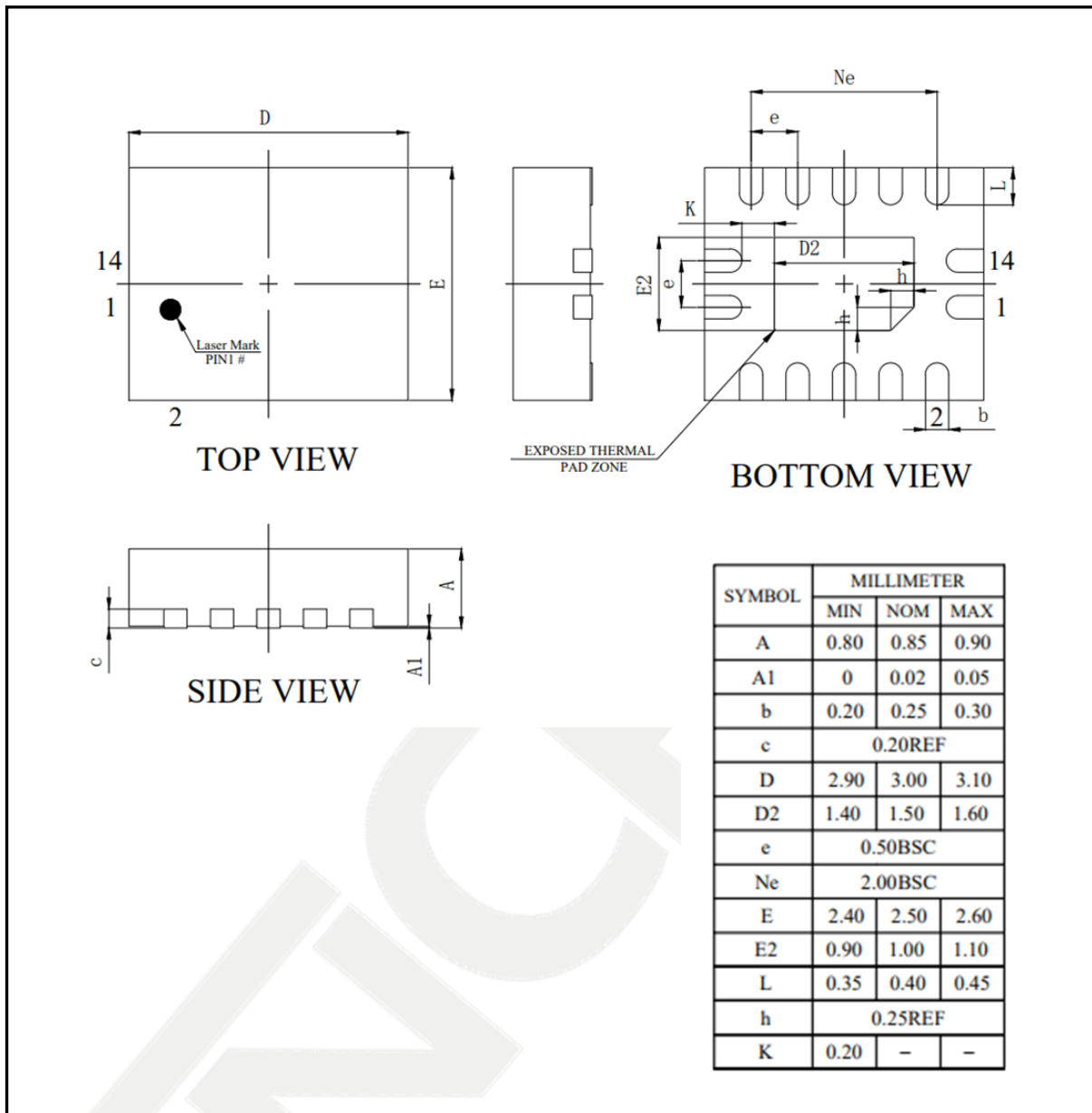

Figure 23 TSSOP14 Mechanical Data and Package Dimensions

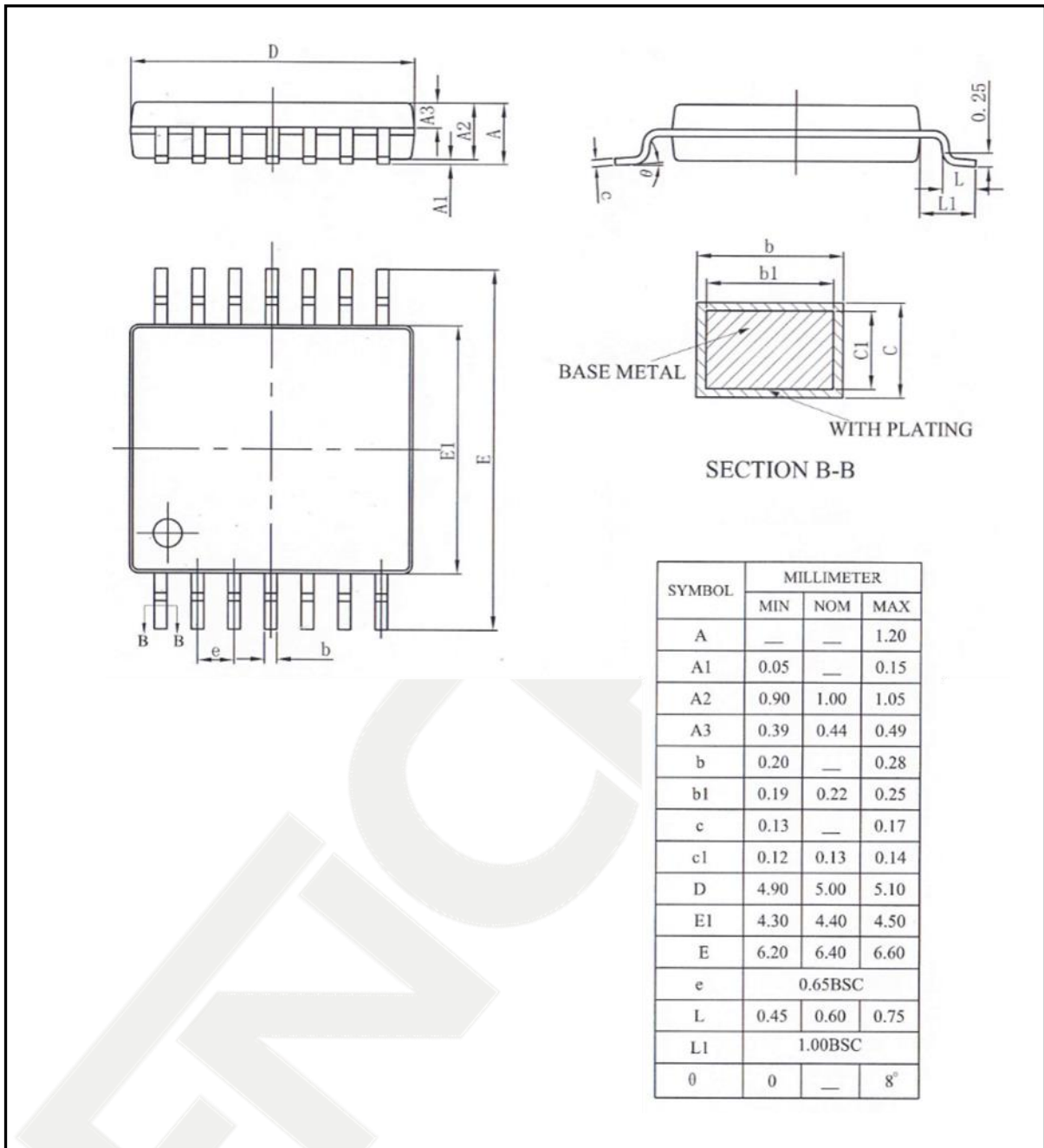
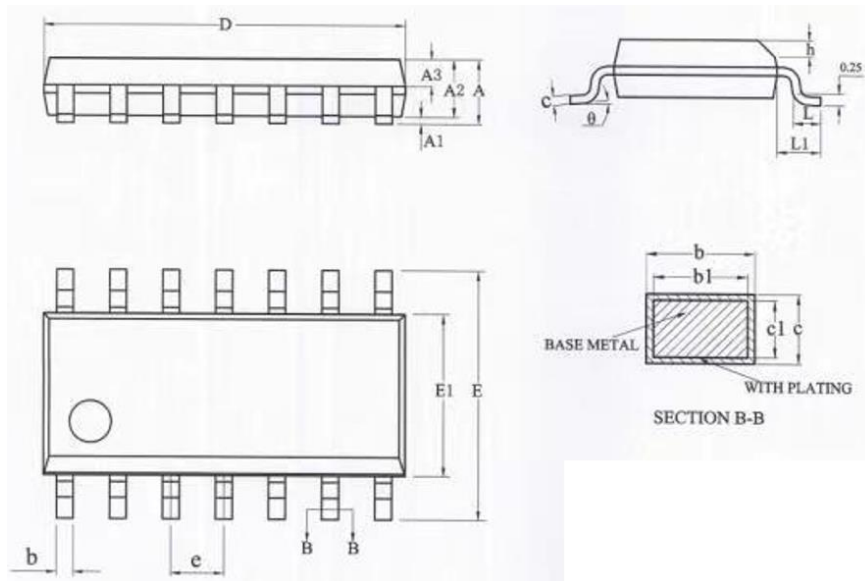



Figure 24 SOP14 Mechanical Data and Package Dimensions



SYMBOL	MILLIMETER		
	MIN	NOM	MAX
A	—	—	1.75
$\Delta$ A1	0.10	—	0.225
A2	1.30	1.40	1.50
A3	0.60	0.65	0.70
$\Delta$ b	0.39	—	0.47
$\Delta$ b1	0.38	0.41	0.44
$\Delta$ c	0.20	—	0.24
c1	0.19	0.20	0.21
$\Delta$ D	8.55	8.65	8.75
E	5.80	6.00	6.20
$\Delta$ E1	3.80	3.90	4.00
e	1.27BSC		
h	0.25	—	0.50
L	0.50	—	0.80
L1	1.05REF		
$\theta$	0	—	$8^\circ$

Figure 25 QFN16 Mechanical Data and Package Dimensions

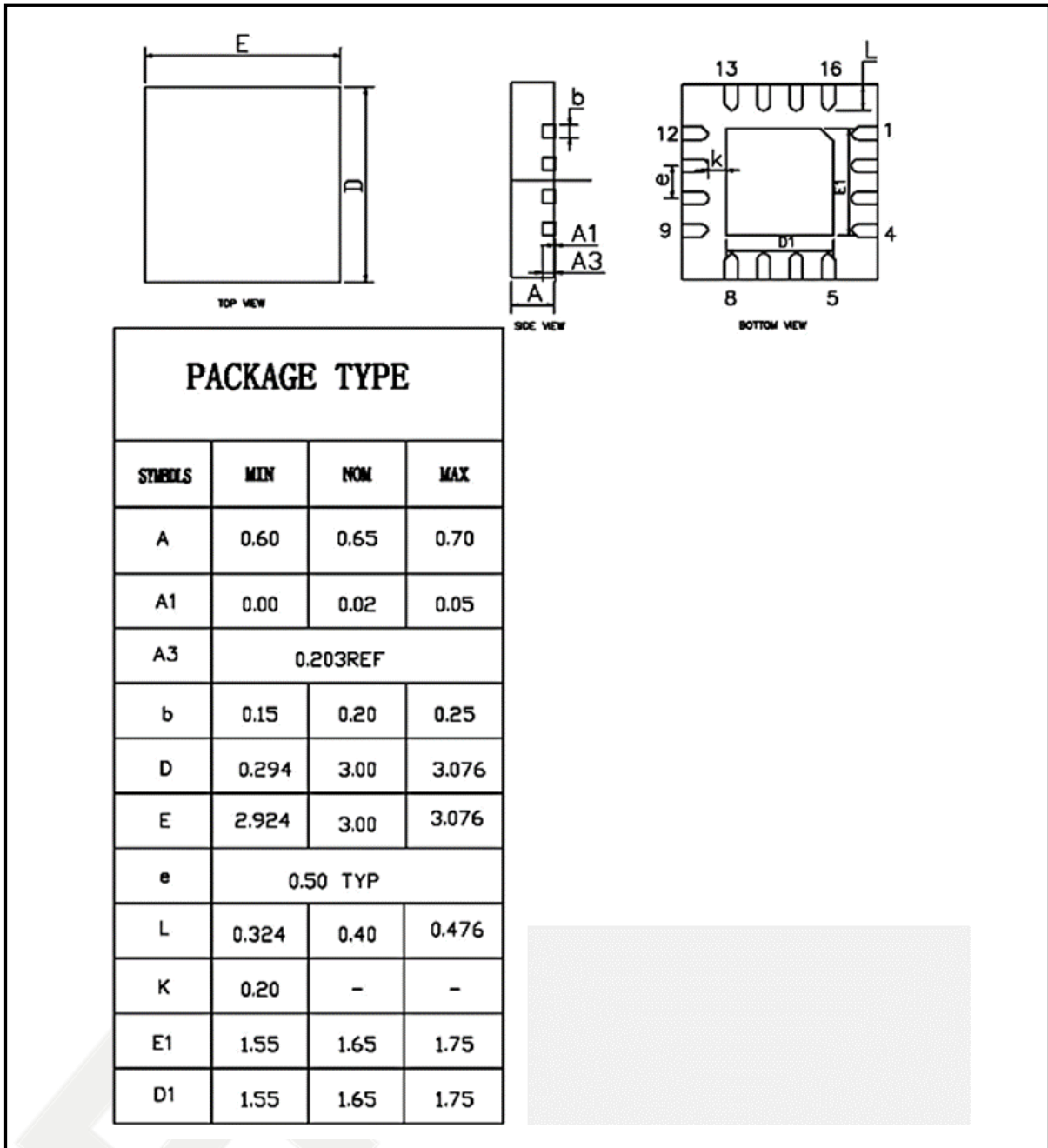
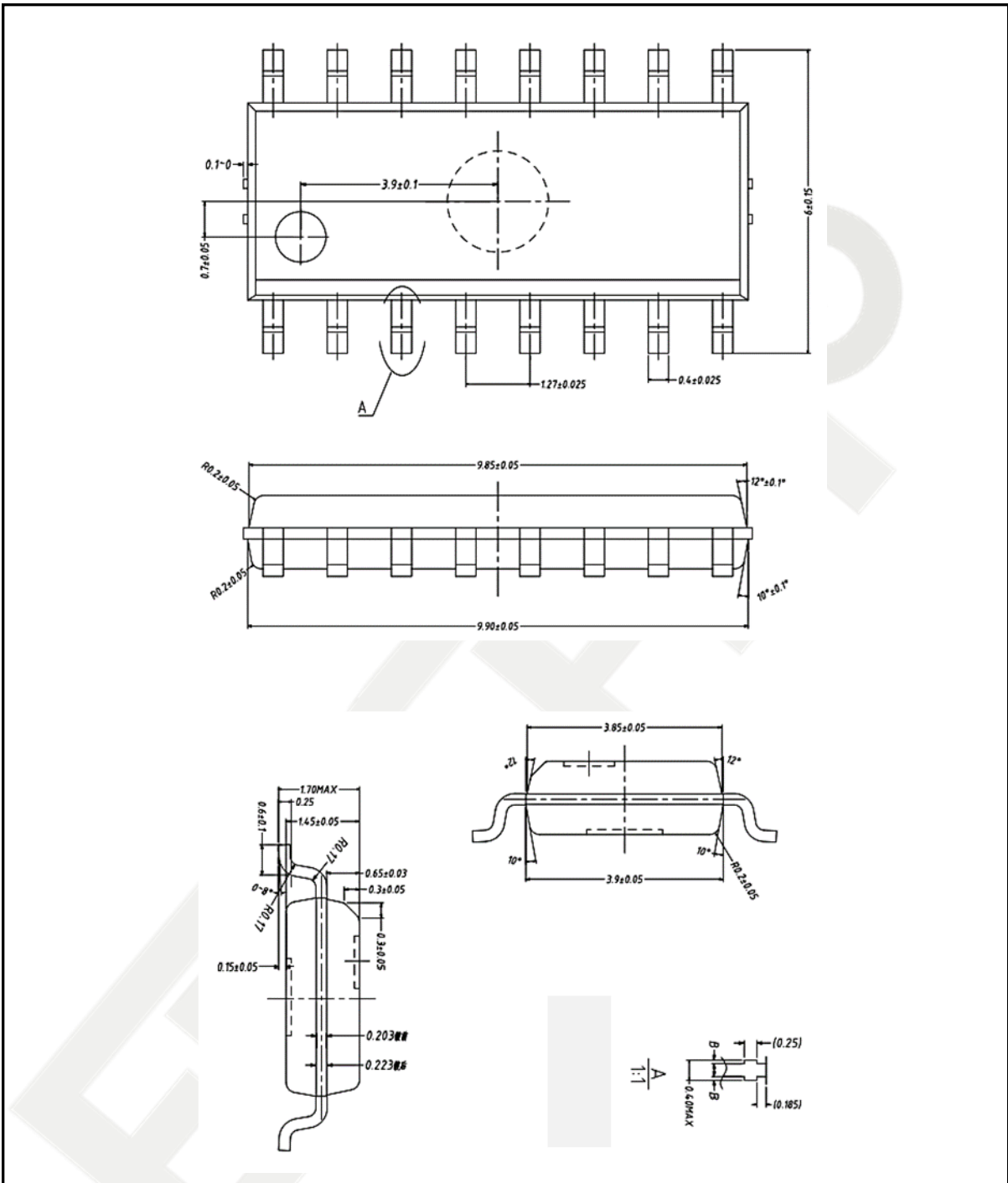

Figure 26 SOP16 Mechanical Data and Package Dimensions



## 5.2 Marking Information

Figure 27 eSOP8 Marking Information

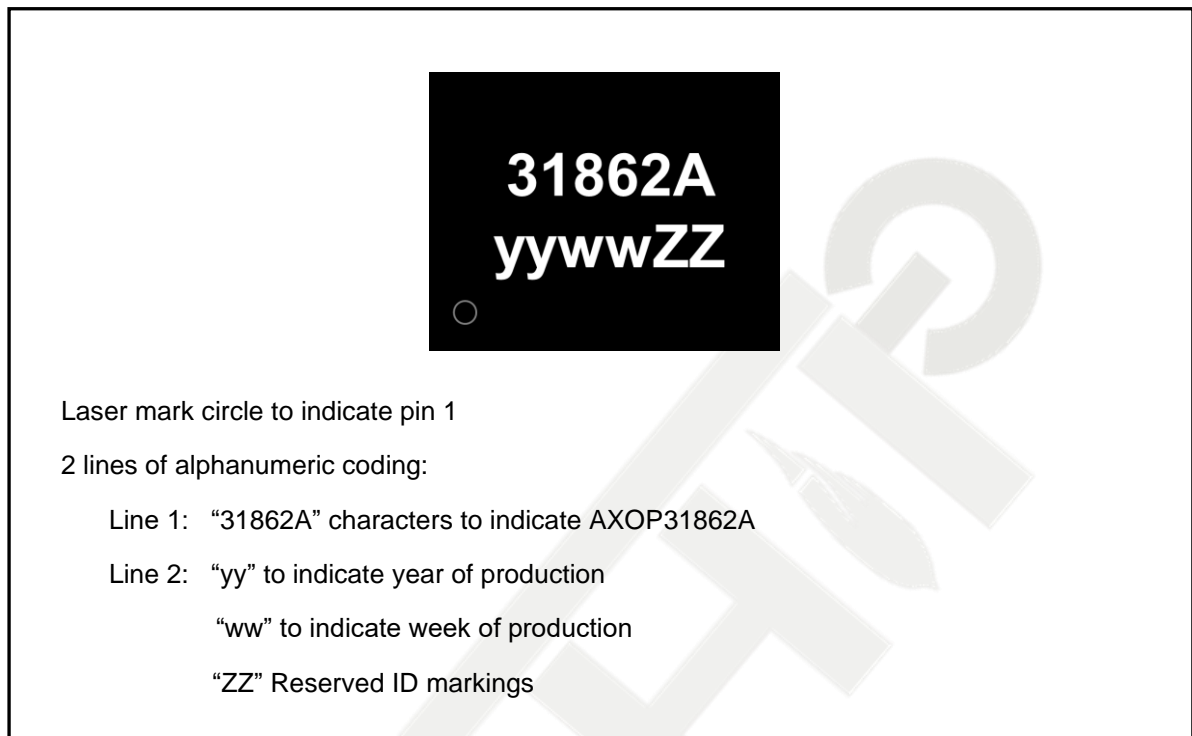

Figure 28 DFN8 Marking Information

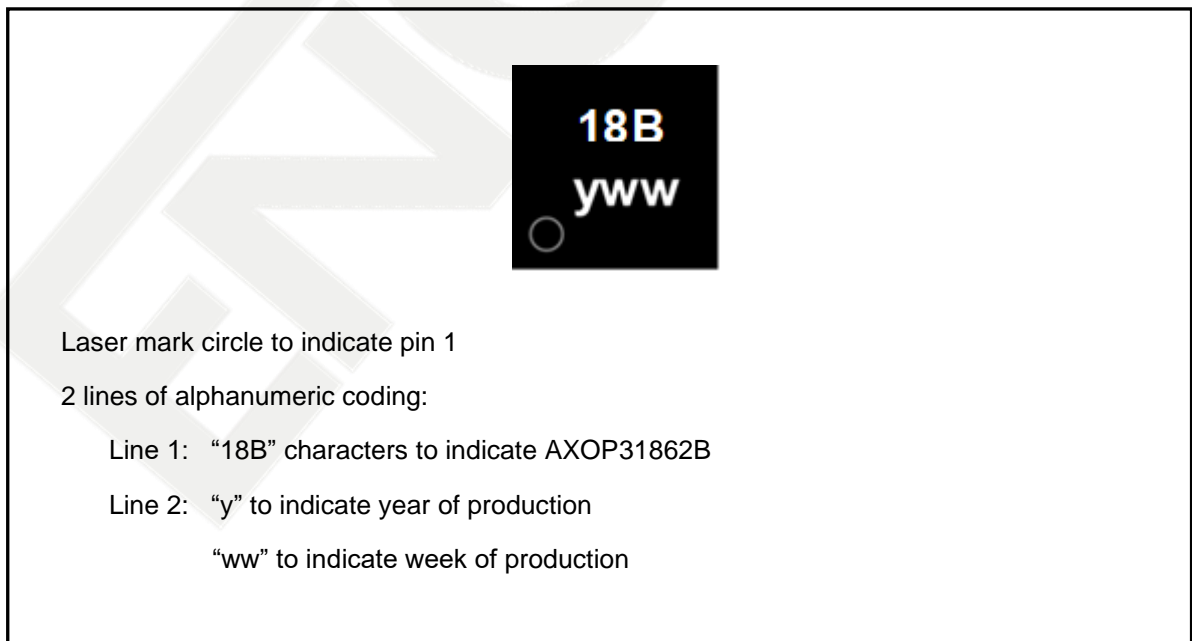

Figure 29 SOP8 Marking Information

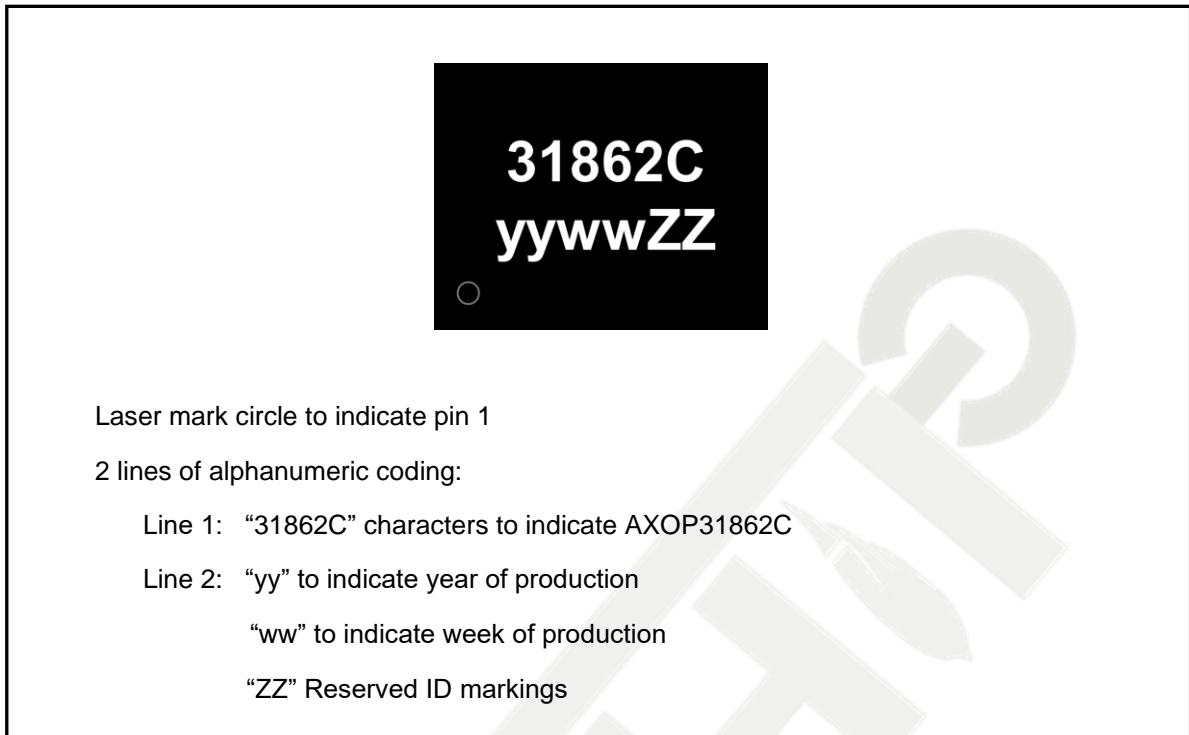

Figure 30 SOT23-8L Marking Information

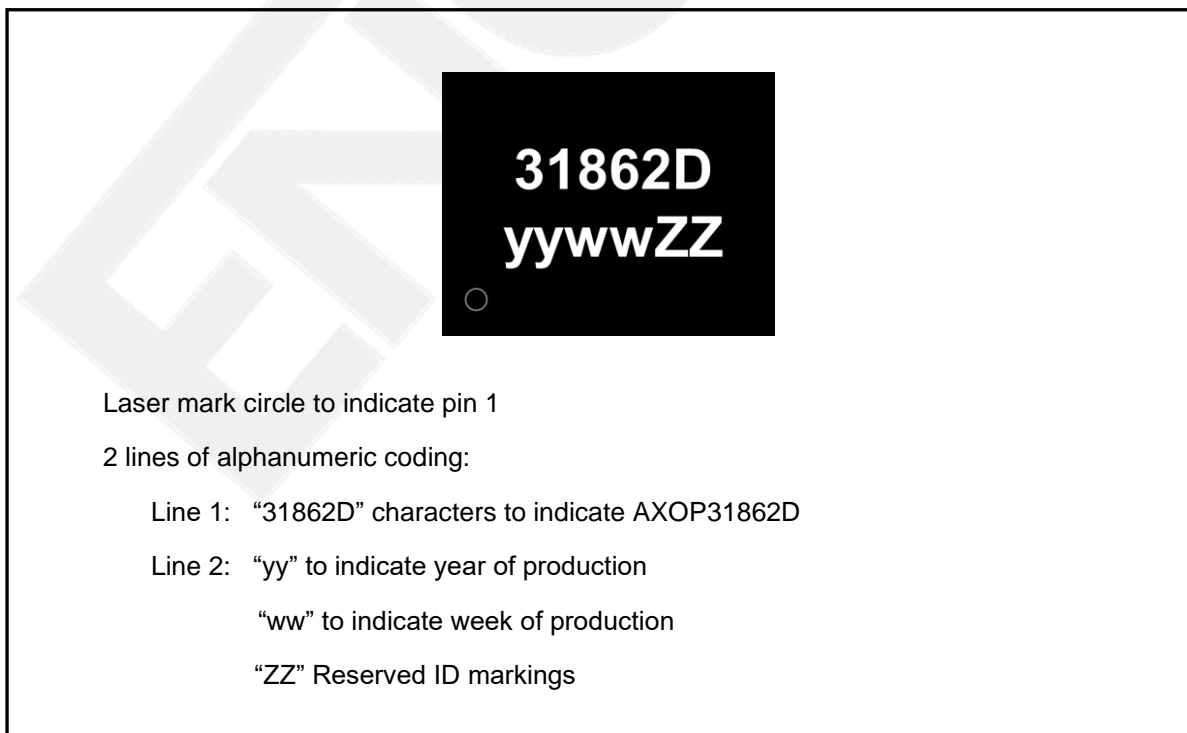

Figure 31 DIP8 Marking Information

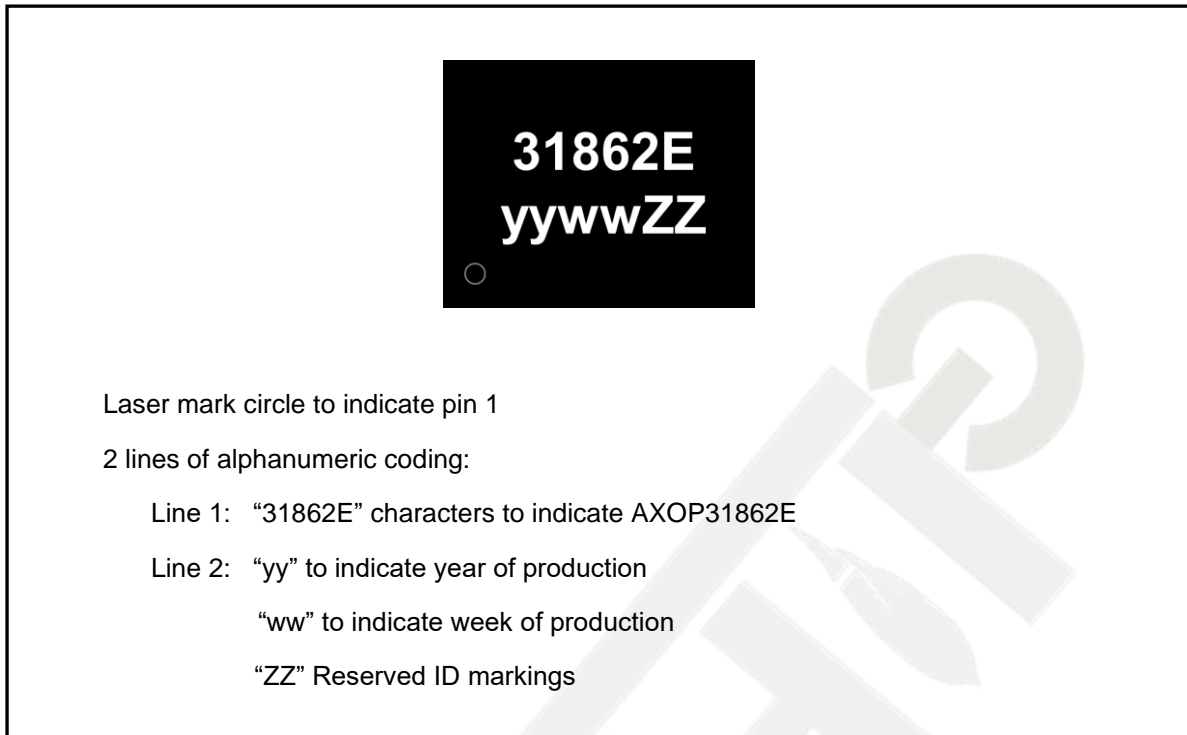

Figure 32 DFN10 Marking Information

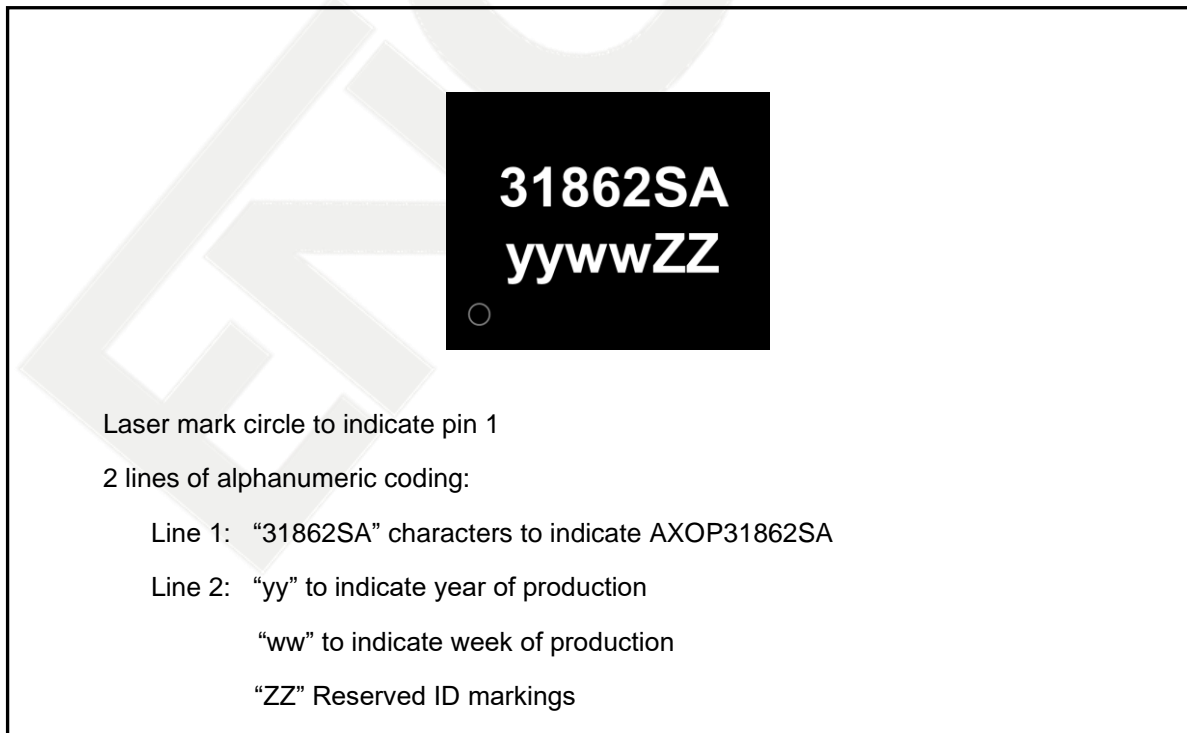

Figure 33 SSOP10 Marking Information

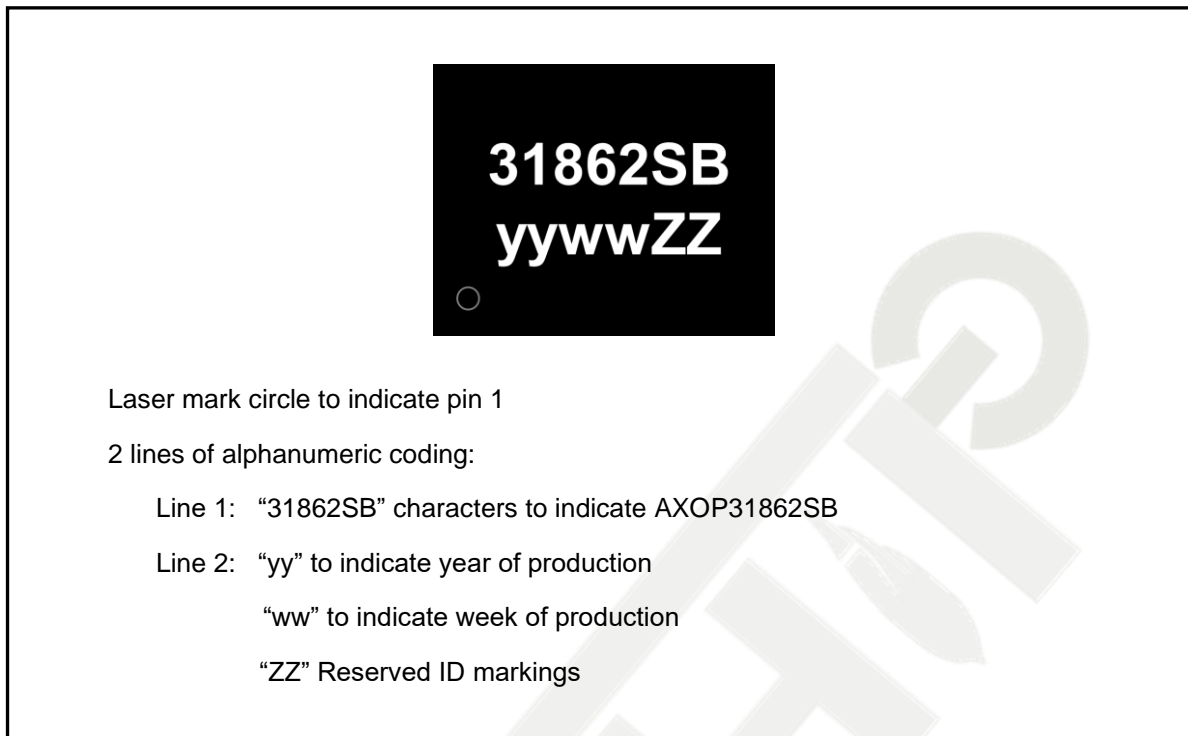

Figure 34 QFN14 Marking Information

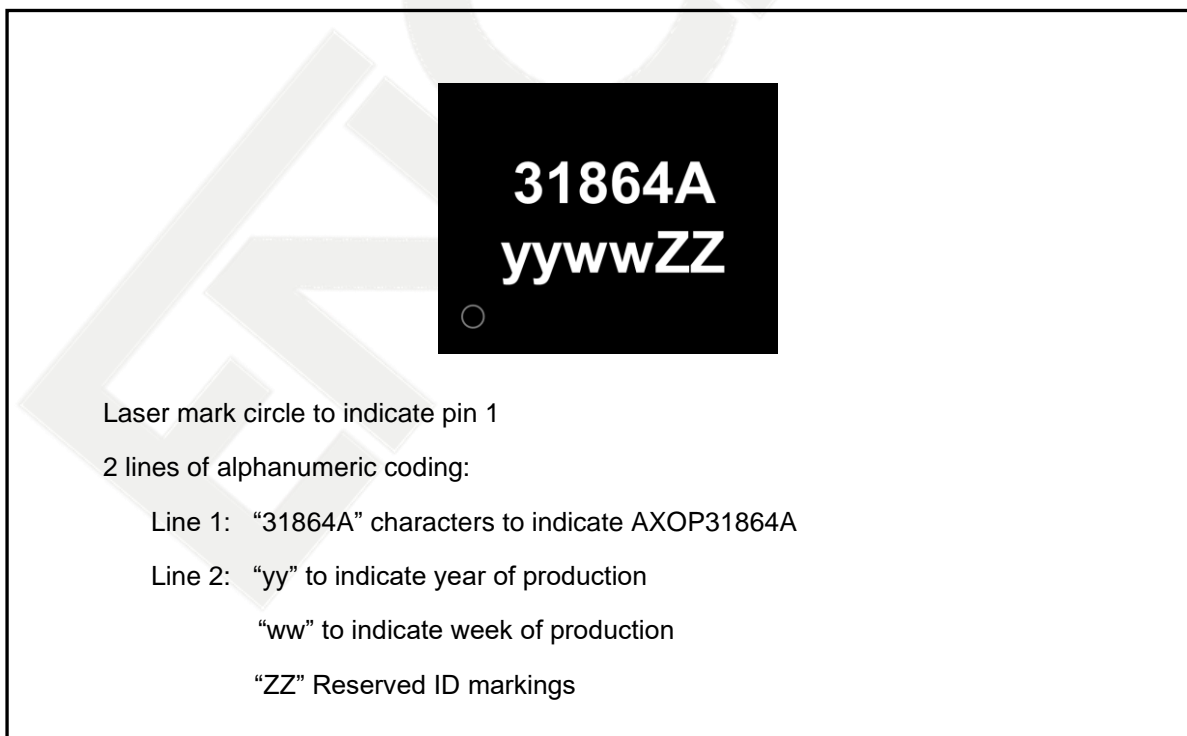

Figure 35 TSSOP14 Marking Information

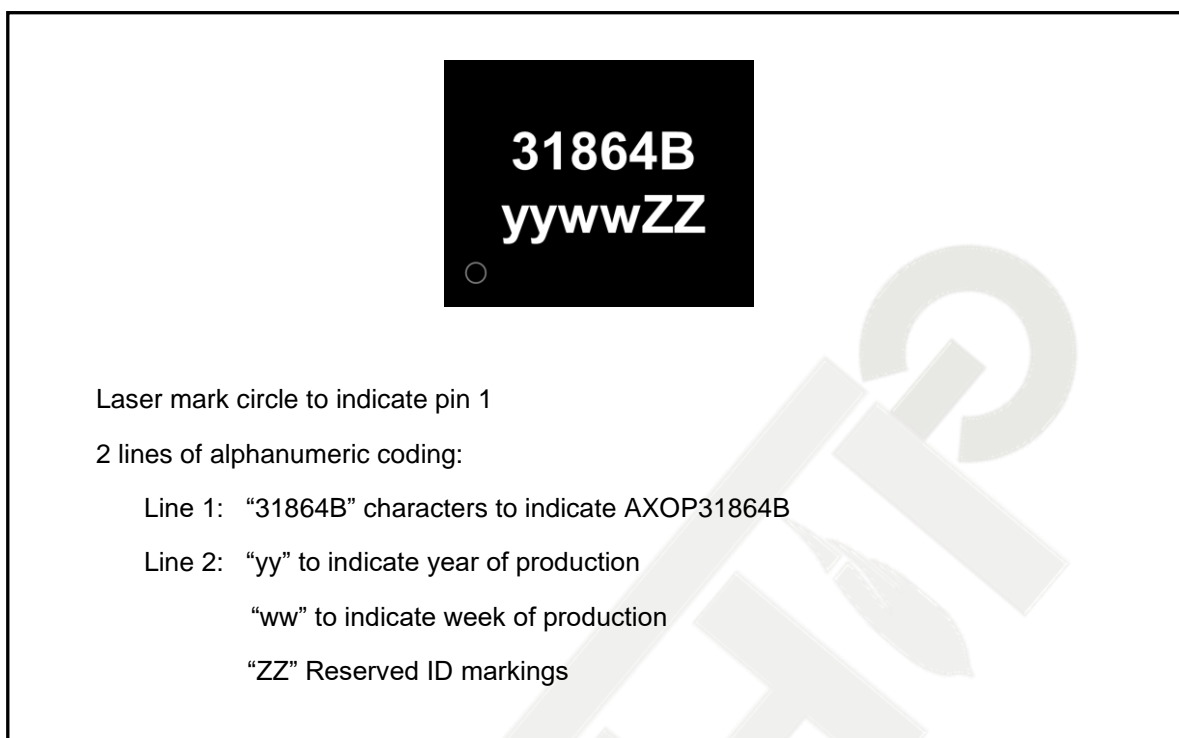

Figure 36 SOP14 Marking Information

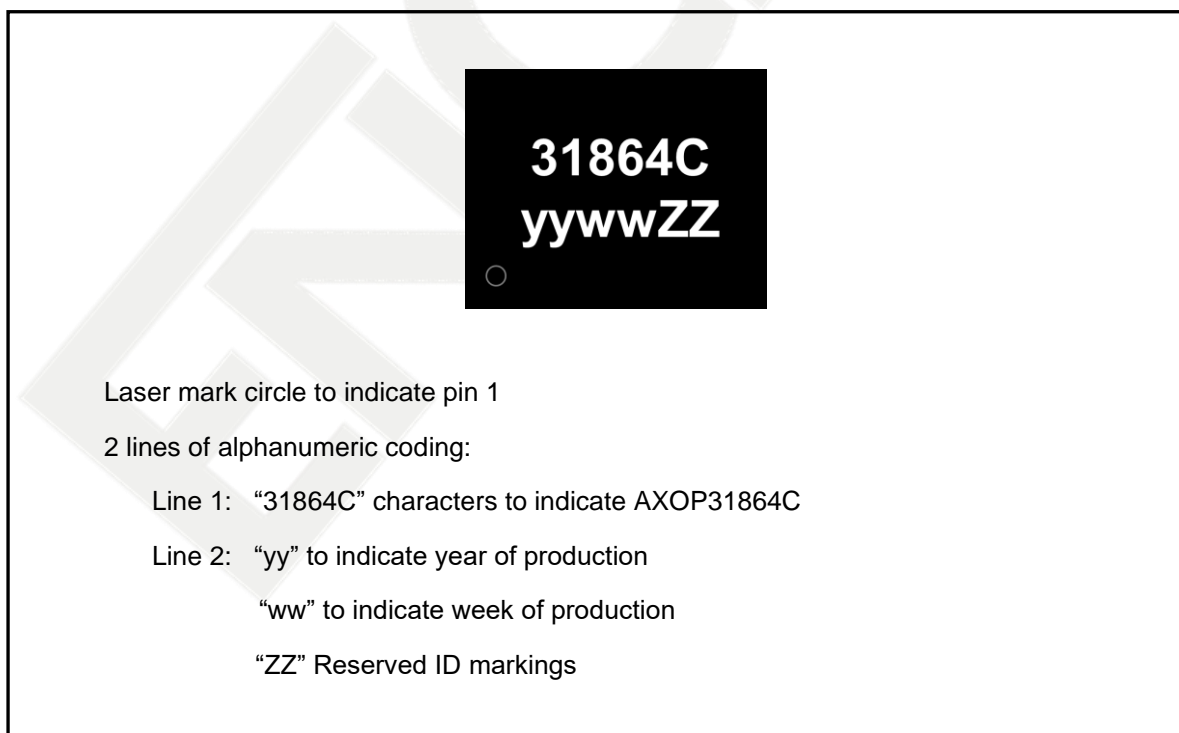



Figure 37 QFN16 Marking Information

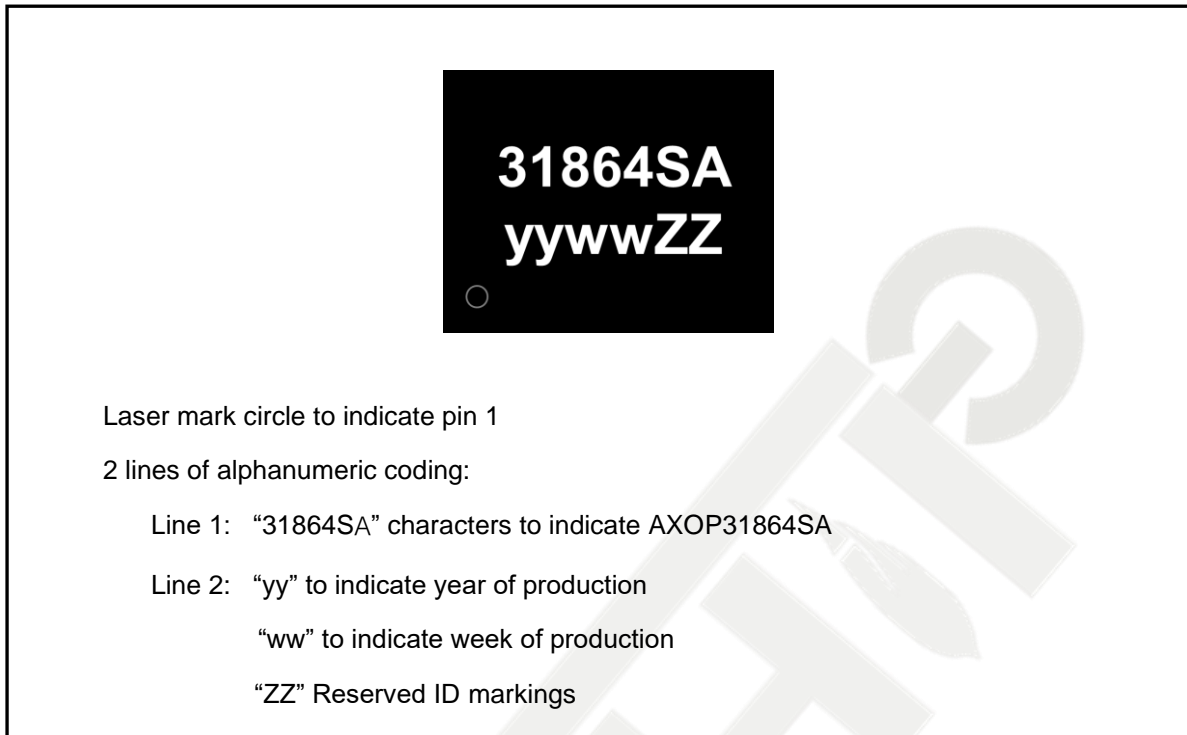
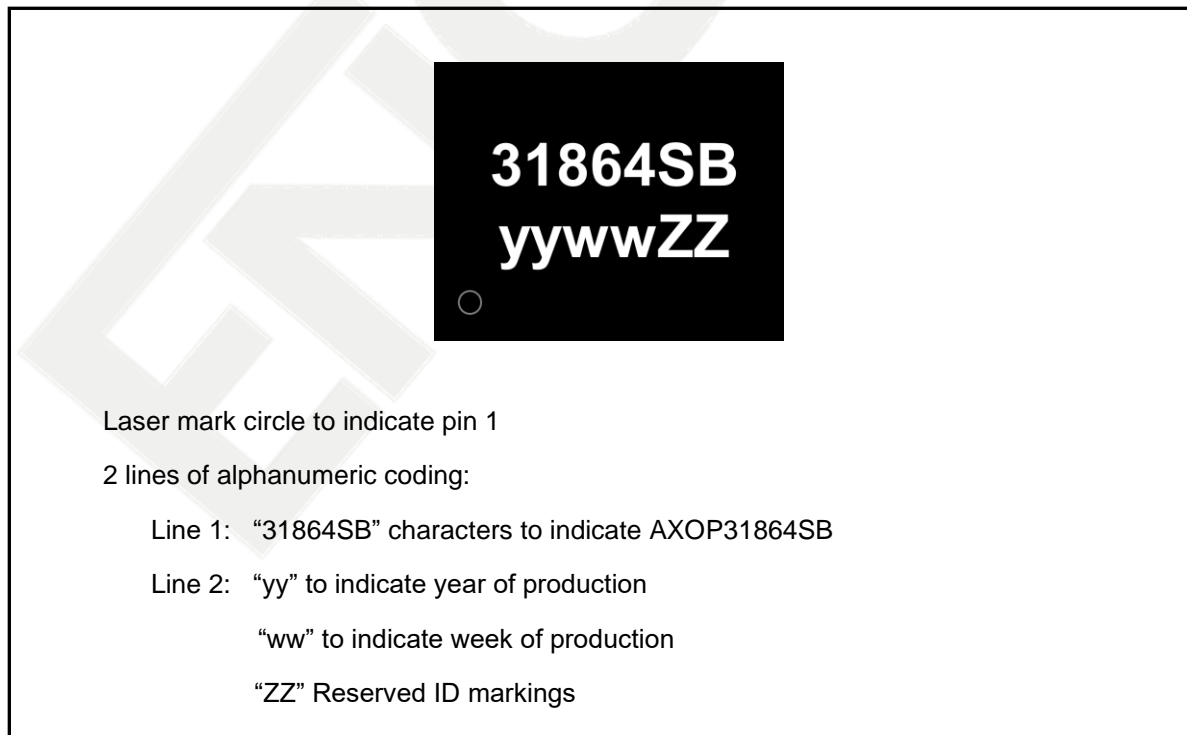
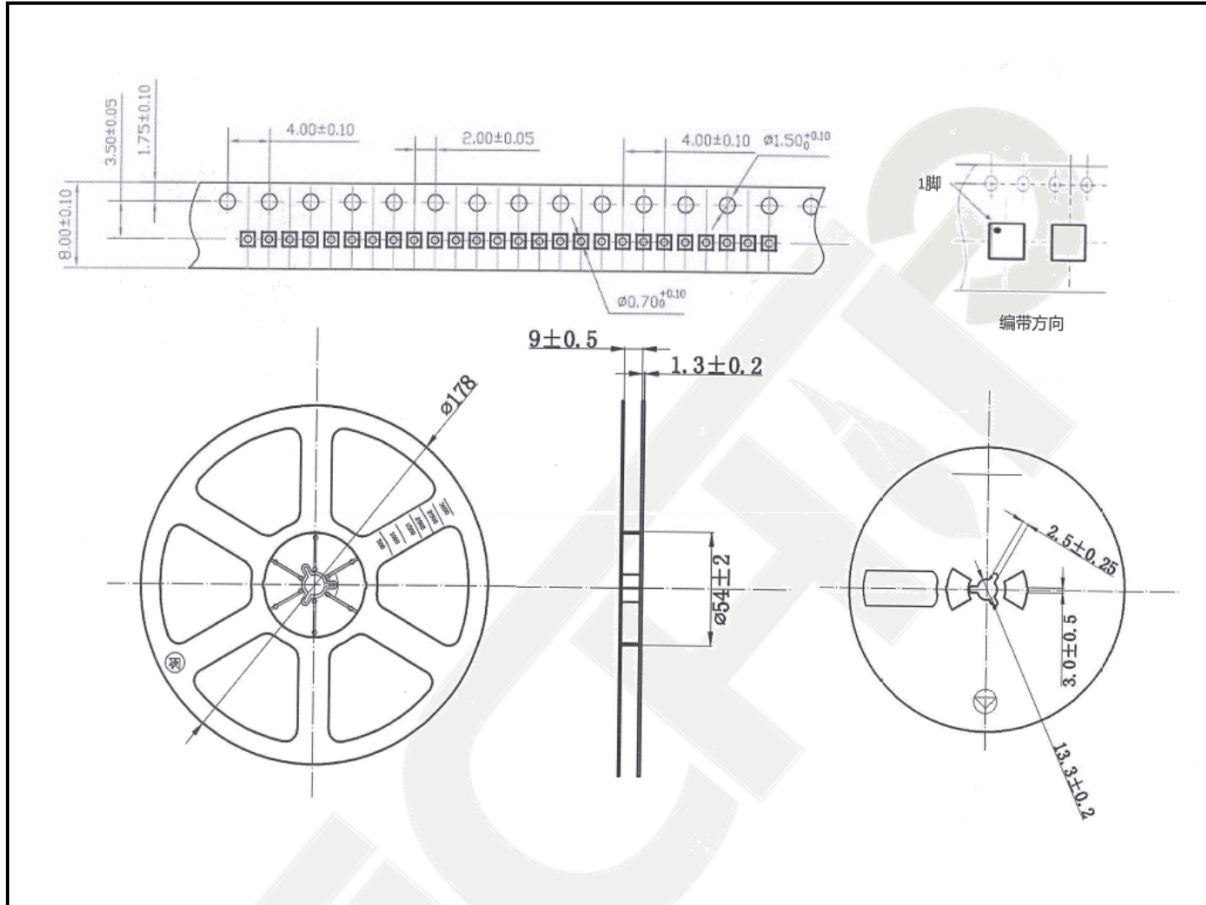

Figure 38 SOP16 Marking Information



## 6 Packing Information

Figure 39 Reel Packing Information



## 7 Revision History

Table 6 Document Revision History

Date	Version	Description
May 2023	1.00	V1.00 version.